

Features & Benefits

- -55°C Operating Temperature
- Digital Control
- Isolated DC-DC Quarter Brick
- 92% Efficiency at Full Load
- Input Under Voltage Lockout
- Output Over Voltage Protection
- Output Current Limit
- Short Circuit Protection
- Thermal Shutdown
- Remote ON/OFF Control
- Output Voltage Trim Range +7%, -30%
- Floating Output Voltage Operation Requires Calibration.

Compliance

Converter (with a Passive EMI filter) is designed to meet:

- MIL-STD-461G
- MIL-STD-810G
- MIL-STD-1275E

Typical Applications

- Military/Defense Power Systems
- Armored Vehicles
- Land Platforms
- Aerospace Platforms
- Communications and Radar Systems
- Medical Systems

Product Ratings	
V _{IN}	18 – 40 V
V _{OUT}	28 V
I _{OUT}	10.7 A
P _{OUT}	300 W

Product Description

Quarter Brick is a 300 W DC/DC converter in quarter-brick size that operates from nominal 28 V input and generates 28 V isolated output. It is designed to meet MIL-STD-461 EMI requirements when combined with the Passive EMI filter module and has superior noise and ripple performance. Converter is fully protected to operate reliably under all kinds of disturbances. Baseplate is designed and manufactured in house to provide efficient cooling and safe operation at 100 °C base plate temperature.



Size: 58.4 x 36.8 x 12.7 mm
[2.3" x 1.45" x 0.5"]

Weight: 95 ± 5 g

Electrical Characteristics

All data are obtained at nominal line and full load unless otherwise specified. (Ta = 25 °C)

Input Characteristics					
Parameters	Notes & Conditions	Min	Typ	Max	Unit
Non-Operating Input Voltage Range	Continuous	-1		60	V
Operating Input Voltage Transient	1s			50	V
Operating Input Voltage Range		18	28	40	V
Under Voltage Turn-On Threshold		15.1	15.6	16.1	V
Under Voltage Turn-Off Threshold		14.2	14.7	15.2	V
No-Load Input Current			162	251	mA
Disabled Input Current			12		mA
Recommended External Input Capacitance	Typ. ESR 0.1-0.2 Ω; See Figure 12		440		μF
Recommended External Input Fuse	Fast acting			30	A

Output Characteristics					
Parameters	Notes & Conditions	Min	Typ	Max	Unit
Output Voltage			28		V
Output Voltage Set Point			± 1		%
Output Voltage Line Regulation			± 0.25		%
Output Voltage Load Regulation			± 0.35		%
Output Voltage Ripple and Noise (pk-pk)	20 MHz bandwidth		356	400	mV
Operating Output Current Range		0		10.7	A
Output Current Limit		11			A
Output Current Shutdown Limit			15.5		A
Output DC Current-Limit Shutdown Voltage			14		V
Output Power			300		W
Maximum Output Capacitance	Nominal output voltage			2.35	mF
Input Voltage Transient Response	50 V/ms; See Figure 12				
Step Change	28V to 40V to 28V input voltage		3.8	4	V
Settling Time	Within 1% output voltage		5		ms
Load Current Transient Response	1 A/μs; See Figure 2 and Figure 5				
Step Change	50% to 75% to 50% output load		0.8		V
Settling Time	Within 1% output voltage		50		μs
Output Voltage Trim Range		-30		+7	%
Recommended External Output Capacitance	Typ. ESR 0.3-0.4 Ω; See Figure 12		100		μF
Output Over-Voltage Protection			33.6		V

General Characteristics					
Parameters	Notes & Conditions	Min	Typ	Max	Unit
Efficiency	From half load to full load	91		92.3	%
Turn-On Transient Time	Within 90% output voltage		35		ms
Turn-On Transient Output Voltage Overshoot	Maximum output capacitance		1		%
Soft-Start Time	Within 90% output voltage		5		ms
Switching Frequency			150		kHz
Non-Operating ON/OFF Pin Voltage	Continuous	-1		60	V
ON/OFF Control Off-State Voltage		1.1		40	V
ON/OFF Control On-State Voltage		-1		0.9	V
MTBF	Ground Benign, 30°C Ta		4593		10 ³ Hrs.
	Ground Fixed, 40°C Ta		586		10 ³ Hrs.
	Ground Mobile, 45°C Ta		232		10 ³ Hrs.
Over Temperature Shutdown Trip Point			115		°C
Over Temperature Shutdown Hysteresis			15		°C

Isolation Characteristics					
Parameters	Notes & Conditions	Min	Typ	Max	Unit
Insulation Resistance	500V _{DC}				
Input to Base Plate			>45		GΩ
Output to Base Plate			>45		GΩ
Isolation Voltage	60s dwell, 1mA trip current				
Input to Output			500		V _{DC}
Input to Base Plate			500		V _{DC}
Output to Base Plate			500		V _{DC}

Environmental Characteristics						
Parameters	Standard	Min	Typ	Max	Unit	Status
Operational Baseplate Temperature	MIL-STD-810G_CHG-1 Method 501.6/502.6 Procedure II	-55	-	+100	°C	Passed*
Storage / Transport Temperature	MIL-STD-810G_CHG-1 Method 501.6/502.6 Procedure I	-55	-	+125	°C	Passed*
Operational Low Pressure	MIL-STD-810G_CHG-1 Method 500.6 Procedure II	-	-	3000	m	Passed*
Storage / Transport Low Pressure	MIL-STD-810G_CHG-1 Method 500.6 Procedure I	-	-	9000	m	Designed to Meet
Parameters	Standard	Waveform	Peak Value	Pulse Duration	Axis	Status
Shock	MIL-STD-810G_CHG-1 Method 516.7 Procedure I	Half-Sine	10g	11 ms	±X, ±Y, ±Z	Passed*
Parameters	Standard	Category	Figure	Platform	Vehicle	Status
Vibration	MIL-STD-810G_CHG-1 Method 514.7 Procedure I	Category 4	514.7C-2	Secured Cargo	Truck Transportation and Composite Wheeled Vehicles	Passed*
		Category 8	514.7C-8	Aircraft	Propeller	Passed*
		Category 11	514.7C-11	Railroad	Train	Passed*
		Category 20	514.7C-4	Ground	Wheeled Vehicles	Passed*
		Category 21	514.7D-9	Watercraft	Marine Vehicles	Passed*
Parameters	Standard	Condition				Status
Salt Fog	MIL-STD-810G_CHG-1 Method 509.6	24 hours spray, 24 hours dry, applied 2 times				Designed to Meet
Sand and Dust	MIL-STD-810G_CHG-1 Method 510.6 Procedure I/II	<150 µm Dust 150-850 µm Sand				Designed to Meet
Fungus	MIL-STD-810G_CHG-1 Method 508.7	Analysis of the degree of inertness to fungus growth of the components.				Analysis
Solar Radiation	MIL-STD-810G_CHG-1 Method 505.6 Procedure I	A2				Passed*
Humidity	MIL-STD-810G_CHG-1 Method 507.6 Procedure II	≥ %95 Relative @30°C				Passed*
Parameters	Standard	Test				Status
EMI/EMC	MIL-STD-461G Ground Army	CE102	CS101 CS114 CS115 CS116 CS118	RE102	RS103	Passed*

* Verified in a multi-channel power supply with an Passive EMI filter.

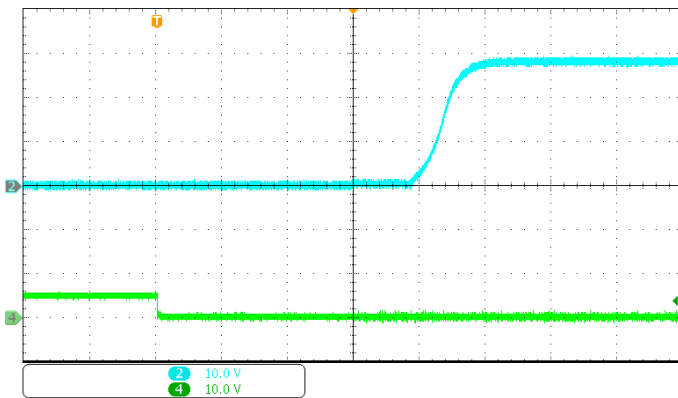

Output voltage (blue) (10 V/div) Time base: 10 ms/div
ON/OFF pin voltage (green) (10 V/div)

Figure 1. Startup waveform, input voltage pre-applied with 1 μF ceramic and 100 μF electrolytic capacitor across the load terminals

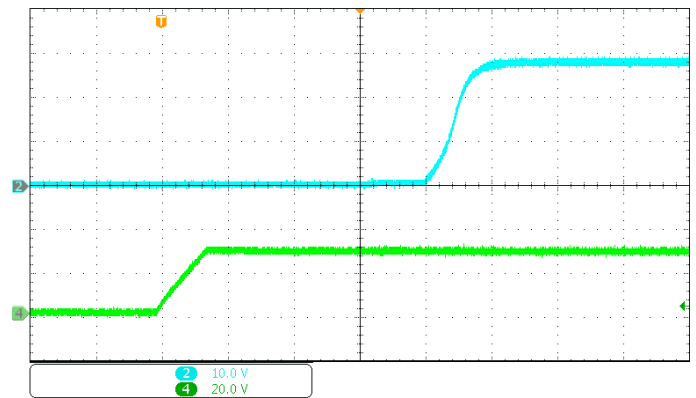

Output voltage (blue) (10 V/div) Time base: 10 ms/div
Input voltage (green) (20 V/div)

Figure 4. Turn on transient at full resistive load with 1 μF ceramic and 100 μF electrolytic capacitor across the load terminals

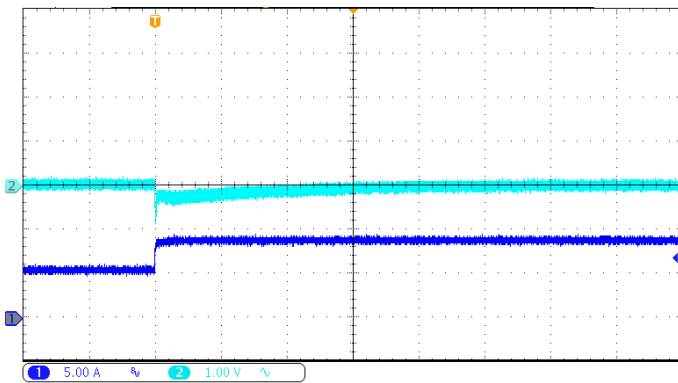

Output voltage (blue) (1 V/div) Time base: 200 μs /div
Output current (navy blue) (5 A/div)

Figure 2. Load current transient response (AC Coupled): from 50% to 75% with 1 μF ceramic and 100 μF electrolytic capacitor across the load terminals ($di/dt = 1 \text{ A}/\mu\text{s}$).

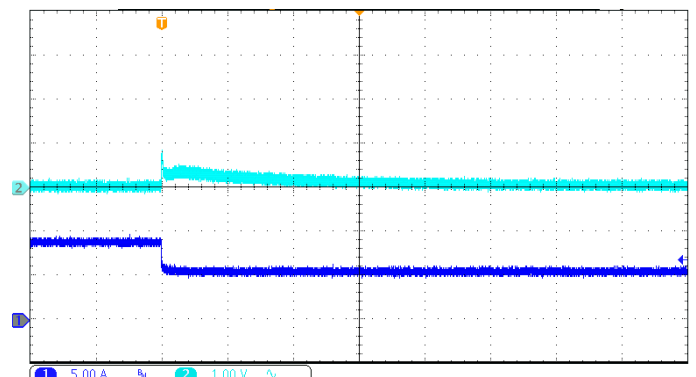

Output voltage (blue) (1 V/div) Time base: 200 μs /div
Output current (navy blue) (5 A/div)

Figure 5. Load current transient response (AC Coupled): from 75% to 50% with 1 μF ceramic and 100 μF electrolytic capacitor across the load terminals ($di/dt = 1 \text{ A}/\mu\text{s}$).

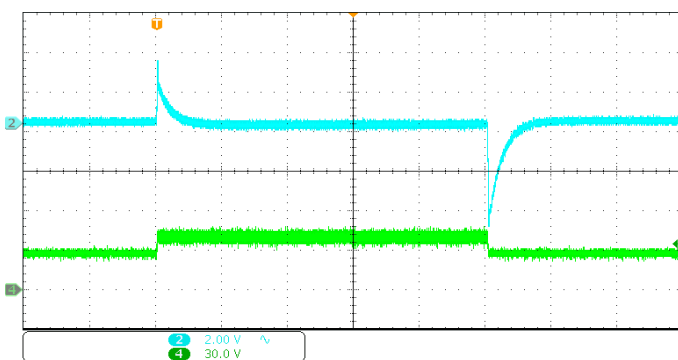

Output voltage (blue) (2 V/div) Time base: 10 ms/div
Input voltage (green) (30 V/div)

Figure 3. Input voltage transient response (AC Coupled): from 28 V to 40 V and back to 28 V with 1 μF ceramic and 100 μF electrolytic capacitors across the load terminals ($dV/dt = 50 \text{ V}/\text{ms}$).

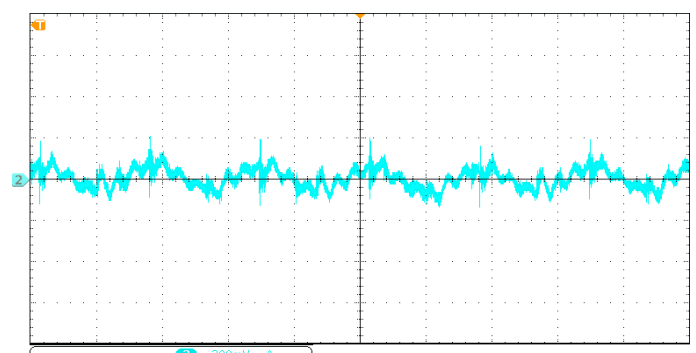

Output voltage ripple (200 mV/div) Time base: 2 μs /div

Figure 6. Output voltage ripple at nominal input voltage and full load current with 1 μF ceramic and 100 μF electrolytic capacitor across the load terminals.

Bandwidth: 20 MHz

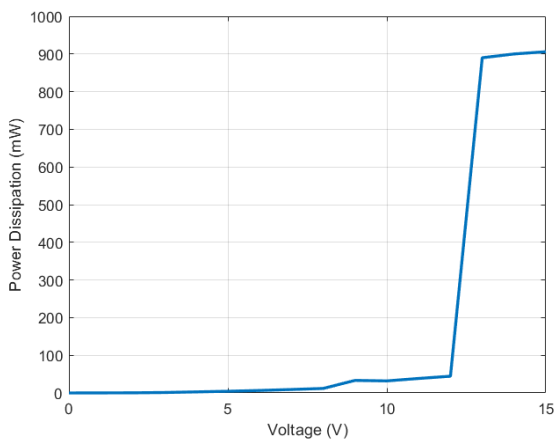

Figure 7. Disabled power dissipation versus input voltage

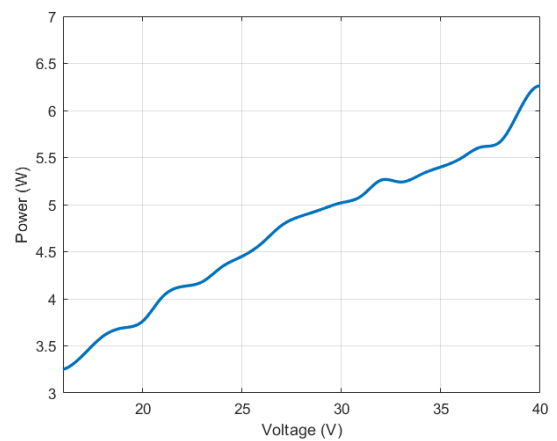

Figure 10. Enabled power dissipation versus input voltage

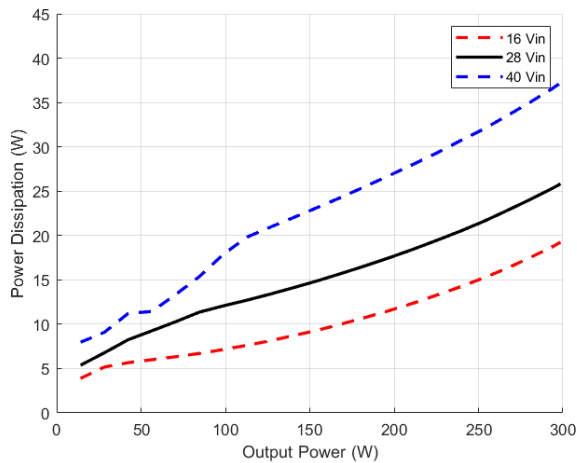

Figure 8. Power dissipation versus output power at minimum, nominal, and maximum input voltage

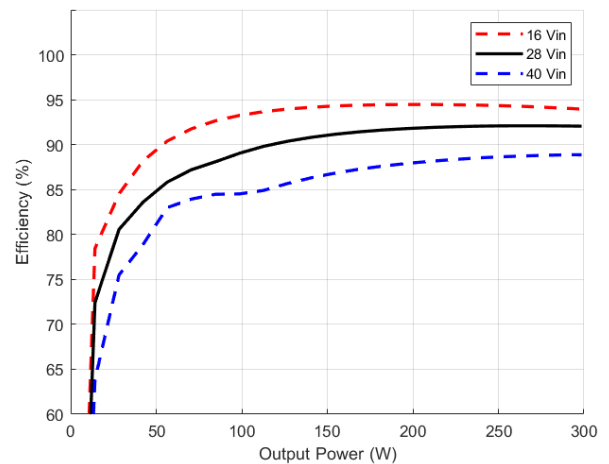

Figure 11. Efficiency versus output power at minimum, nominal, and maximum input voltage

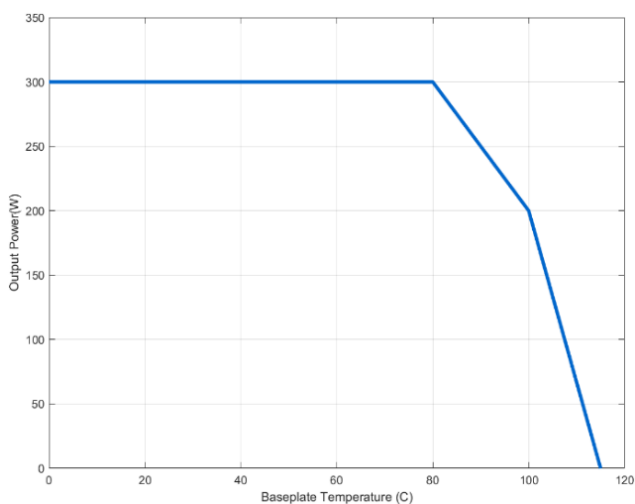

Figure 9. Thermal Derating (maximum output power vs baseplate temperature) at nominal input voltage

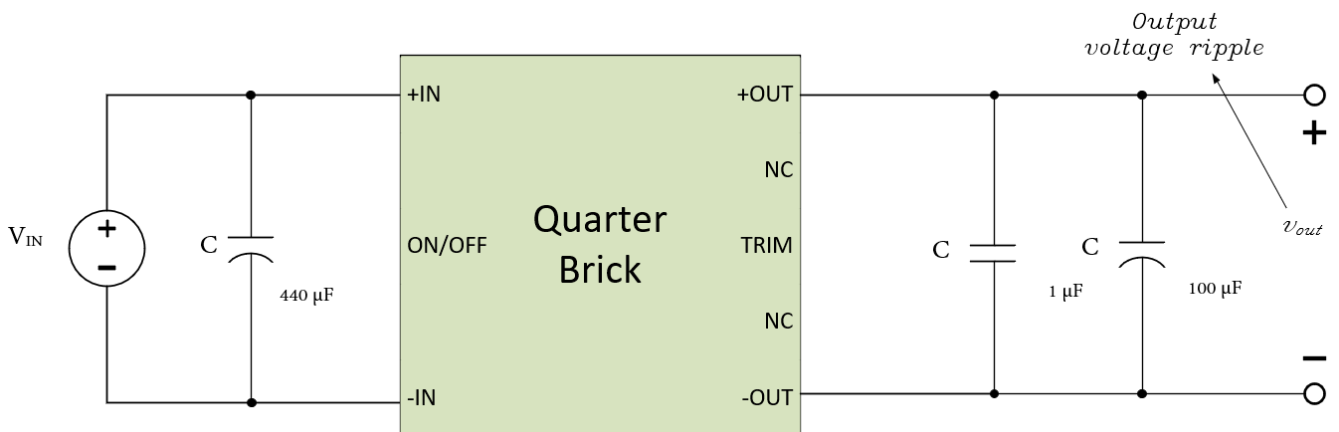

Figure 12. Test set-up showing measurement point for output voltage ripple.

Basic Operation and Features

REMOTE ON/OFF

The ON/OFF input, Pin 2, allows the user to control the ON and OFF states of the module. This input, which is referenced to the return terminal of the input bus (-IN), is held as active low to keep the module at ON state. If it is left floating, converter goes into OFF state. Moreover, the ON/OFF function allows the product to be turned on/off by an external device like a semiconductor or a mechanical switch.

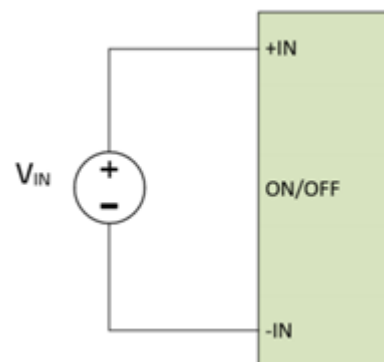

Figure 15. Recommended OFF State Connections

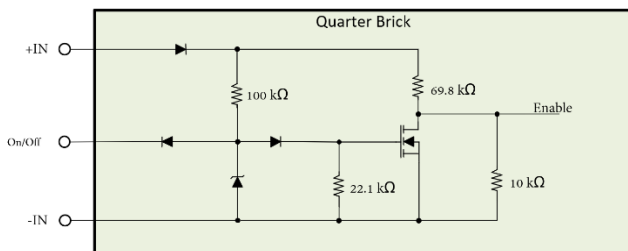

Figure 13. Internal ON/OFF Circuit

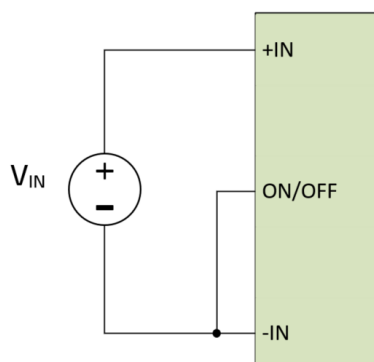

Figure 14. Recommended ON State Connection

OUTPUT VOLTAGE TRIM

TRIM input feature of the module permits the user to adjust the output voltage across the output leads up or down according to the trim range. To decrease the output voltage, the user should connect a resistor between TRIM and +OUT input. A 0 Ω resistor is permissible for trim-up configuration. However, for trim-down configuration, the trim resistor value should not be less than 19.334 kΩ.

For a desired decrease of the nominal output voltage, the value of the resistor should be calculated as below.

$$R_{TRIM_DOWN} = 27.95 * \frac{(V_{OUT_{nom}} - V_{OUT_{desired}} * 1.725)}{(V_{OUT_{desired}} - V_{OUT_{nom}})} \text{ k}\Omega$$

Output Voltage resulting from trim down resistor can be calculated as below. R_{TRIM_DOWN} is trim down resistor's value in $k\Omega$.

$$V_{Generated} = V_{OUT_{nom}} * \frac{(27.95 + R_{TRIM_DOWN})}{(R_{TRIM_DOWN} + 48.22)} V$$

To increase the output voltage, the user should connect a resistor between TRIM and -OUT input. For input voltages below 18 V at full-load, converter is not able to regulate output voltage above 28 V. So, for input voltages lower than 18 V, trim-up capability is limited.

Converter is able to regulate output voltage to 28 V at full load, starting from 18 V input voltage.

For a desired increase of the nominal output voltage, the value of the resistor should be calculated as below.

$$R_{TRIM_UP} = \frac{(27.95 * V_{OUT_{nom}} - V_{OUT_{desired}} * 26.1)}{(V_{OUT_{desired}} - V_{OUT_{nom}})} k\Omega$$

Output Voltage resulting from trim up resistor can be calculated as below. R_{TRIM_UP} is trim up resistor's value in $k\Omega$.

$$V_{Generated} = V_{OUT_{nom}} * \frac{(27.95 + R_{TRIM_UP})}{(R_{TRIM_UP} + 26.1)} V$$

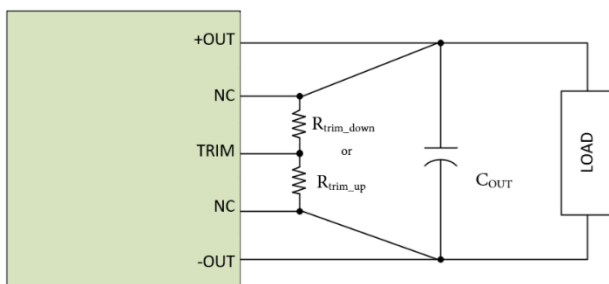

Figure 16. Typical Trim Application Circuit

DROOP CURRENT SHARING

For “droop active” models, output voltage has a 1 V slope from full load to no load. In other words, output voltage of the module is 28.5 V for no load and 27.5 V for full load. This enables safe parallel connection of multiple models.

For connection diagram, please refer to Figure 19. Recommended Application N+1 Redundant Parallel Connection Figure 19. ORing diodes (simple diode or ideal diode) are required for parallel connection.

DIGITAL COMMUNICATION

Parts that have digital communication capability can be accessed using I2C digital interface. This interface can be used to monitor input and output parameters.

Quarter brick module provides a two-wire I2C compatible communication interface that enables host device to monitor device parameters including Input Voltage, Output Voltage and Current, Device Temperature and Status.

I2C PIN DESCRIPTIONS AND RATINGS

Pin Name	Absolute Maximum Voltage Ratings
PMBUS_C2	3.6 V
GND	3.6 V
PMBUS_SDA*	3.6 V
PMBUS_SMBALERT*	3.6 V
PMBUS_SCL*	3.6 V
PMBUS_ADDRESS*	3.6 V

*: Internal 10kOhm pull-up resistor to 3.3 V

I2C SIGNAL SPECIFICATIONS

Parameter	Min	Typ	Max	Unit
High Level Input Voltage	2.64		3.5	V
Low Level Input Voltage	0		1	V
SDA and SCL Bus Capacitive Load			400	pF
Bus Frequency		100		kHz
Clock Low Time	4.7			μs
Clock High Time	4			μs
SDA and SCL Fall Time			300	ns
SDA and SCL Rise Time			1000	ns
Data Input Setup Time	250			ns
Start Condition Setup Time	4.7			μs
Start Condition Hold Time	4.0			μs
Stop Condition Setup Time	4.0			μs
Stop Condition Hold Time	>0			μs
Bus Free Time	4.7			μs

I2C READ OPERATION

Quarter Brick supports 100 kHz bus frequency and always acts as a slave. I2C Master can only read registers of quarter brick. Write to registers is not possible. Read register sequence is detailed in Figure 17.



Figure 17. Read Register Operation

Quarter brick modules incorporate internal 10kOhm pull-up resistors to 3.3V on SDA and SCL lines.

Depending on the bus load SDA and SCL lines may require additional pull-up resistors to 2.8 to 3.5V external supply. Absolute maximum capacitive load on SDA and SCL lines are 400pF.

I2C ID SELECTION

I2C address of device is combination of physical address and Read/Write bit. Default I2C physical address for a quarter brick module is 0x2. Alternate physical I2C address of 0x6 is selected when PMBUS_ADDRESS pin tied to Digital Ground (GND) pin.

PMBUS_ADDRESS Pin State	I2C Address Byte	
	Read	Write
Float	0x3	0x2
Tied to GND	0x7	0x6

I2C REGISTERS

I2C digital interface is used to monitor input, output and status information of converter.

Digital configuration via Write to registers with I2C interface feature for Quarter brick modules will be implemented in the future.

Register Address	R/W	Register Name	Scale Factor	Description
0x79	Read Only	STS	-	Status Register
0x88	Read Only	VIN	1mV/LSB	Input Voltage Reading Register
0x8B	Read Only	VOUT	1mV/LSB	Output Voltage Reading Register
0x8C	Read Only	IOUT	1mA/LSB	Output Current Reading Register
0x8D	Read Only	TEMP	1 °C/LSB	Temperature Reading Register

STATUS REGISTER (STS) 0x79

Status Register (0x79) is a 16-bit register containing status information and last logged fault of brick module.

Status Register (STS)							
15	14	13	12	11	10	9	8
Reserved			LOT	LOC	LREG	LOV	LUV
7	6	5	4	3	2	1	0
Reserved			OT	OC	REG	OV	UV

Eight least significant bits (LSBs) of STS (0x79) holds status information of the device. If any bit is set to 1, this indicates output is turned off due to fault conditions described in Status Register Fields table.

Eight most significant bits (MSBs) of STS (0x79) holds last fault log since power up. Fault log can only be cleared by powering down the converter or by pulling Remote ON/OFF pin to OFF state.

Status Register (STS) Fields			
Bits	Field	Reset	Description
0	UV	0	Input Under Voltage Fault bit 1: Input Voltage is lower than "Under Voltage Turn-Off Threshold". 0: Input Voltage is higher than "Under Voltage Turn-On Threshold".
1	OV	0	Input Over Voltage Fault bit 1: Input Voltage is higher than "Over Voltage Turn-Off Threshold". 0: Input Voltage is lower than "Over Voltage Turn-On Threshold".
2	REG	0	Regulation Fault bit 1: Output Voltage is lower than "Output DC Current-Limit Shutdown Voltage" or higher than "Output Over Voltage Protection Limit". 0: Output Voltage is OK.
3	OC	0	Output Over Current Fault bit 1: Output Current is higher than "Output Current Shutdown Limit". 0: Output Current is in operating limits.
4	OT	0	Over Temperature Fault bit 1: Temperature is higher than "Over Temperature Shutdown Trip Point". 0: Temperature is in operating limits.
5-7	Res	0	Reserved
8	LUV	0	Logged Input Under Voltage Fault bit
9	LOV	0	Logged Input Over Voltage Fault bit
10	LREG	0	Logged Regulation Fault bit
11	LOC	0	Logged Output Over Current Fault bit
12	LOT	0	Logged Over Temperature Fault bit
13-15	Res	0	Reserved

INPUT VOLTAGE REGISTER (VIN) 0x88

Input Voltage Register (0x88) is a 16-bit register containing unsigned input voltage reading information of brick module. This register has a scale factor of 1 mV/LSB.

Input Voltage Register (VIN)							
15	14	13	12	11	10	9	8
VIN [15-8]							
7	6	5	4	3	2	1	0
VIN [7-0]							

Lower 8-bit part of VIN (0x88) register holds eight least significant bits (LSBs) of input voltage reading.

Upper 8-bit part of VIN (0x88) register holds eight most significant bits (MSBs) of input voltage reading.

Input Voltage Register (VIN) Fields			
Bits	Field	Reset	Description
0-15	VIN	0	Input Voltage Reading 0 = 0 V 1 = 0.001 V . . 28000 = 28.0 V . . 50000 = 50.0 V

OUTPUT VOLTAGE REGISTER (VOUT) 0x8B

Output Voltage Register (0x8B) is a 16-bit register containing unsigned output voltage reading information of brick module. This register has a scale factor of 1 mV/LSB.

Output Voltage Register (VOUT)							
15	14	13	12	11	10	9	8
VOUT [15-8]							
7	6	5	4	3	2	1	0
VOUT [7-0]							

Lower 8-bit part of VOUT (0x8B) register holds eight least significant bits (LSBs) of output voltage reading.

Upper 8-bit part of VOUT (0x8B) register holds eight most significant bits (MSBs) of output voltage reading.

Output Voltage Register (VOUT) Fields			
Bits	Field	Reset	Description
0-15	VOUT	0	Output Voltage Reading 0 = 0 V 1 = 0.001 V . . 28000 = 28.0 V . . 50000 = 50.0 V

OUTPUT CURRENT REGISTER (IOUT) 0x8C

Output Current Register (0x8C) is a 16-bit register containing unsigned output current reading information of brick module. This register has a scale factor of 1 mV/LSB.

Output Current Register (IOUT)							
15	14	13	12	11	10	9	8
IOUT [15-8]							
7	6	5	4	3	2	1	0
IOUT [7-0]							

Lower 8-bit part of IOUT (0x8C) register holds eight least significant bits (LSBs) of output current reading.

Upper 8-bit part of IOUT (0x8C) register holds eight most significant bits (MSBs) of output current reading.

Output Current Register (IOUT) Fields			
Bits	Field	Reset	Description
0-15	IOUT	0	Output Current Reading 0 = 0 A 1 = 0.001 A . . 10700 = 10.7 A . . 16500 = 16.5 A

TEMPERATURE REGISTER (TEMP) 0x8D

Temperature Register (0x8D) is a 16-bit register containing temperature reading information of brick module in twos complement format. This register has a scale factor of 1 °C/LSB

Temperature Register (TEMP)							
15	14	13	12	11	10	9	8
TEMP [15-8]							
7	6	5	4	3	2	1	0
TEMP [7-0]							

Lower 8-bit part of TEMP (0x8D) register holds eight least significant bits (LSBs) of temperature reading.

Upper 8-bit part of TEMP (0x8D) register holds eight most significant bits (MSBs) of temperature reading.

Temperature Register (TEMP) Fields			
Bits	Field	Reset	Description
0-15	TEMP	0	Temperature Reading 155: 155 °C . . 1: 1 °C 0: 0 °C 65535: -1 °C . . 65481: -55 °C

Protection Features

Input Under Voltage Lockout

The converter module starts operating when the input voltage is raised above the "Under Voltage Turn-On Threshold." Once turned on, turn off is initiated when the input falls below the "Under Voltage Turn-Off Threshold." The "Module Input Specifications" Table gives the associated limits.

Output Current Limit

The converter will derate the output voltage if the output current exceeds the "Output Current Limit" value. If the fault condition is resolved, the control output voltage will increase to the nominal value.

Output Over Voltage Protection

If the output voltage exceeds the "Output Over Voltage-Protection" value the converter outputs are disabled immediately and retries after cooldown period. The "Output Over Voltage Protection Limit" is 120% of Output Voltage. If trim up or down is used protection limit will change according to output voltage setting.

Output Over Current Protection

If the output current exceeds the "Output Current Shutdown Limit" value the converter outputs are disabled immediately and retries after cooldown period.

Short Circuit Protection

The short circuit condition is an extreme case of the Output Current Limit condition. When Output Voltage drops below "Output DC Current-Limit Shutdown Voltage" limit, the converter outputs are disabled immediately and retries after cooldown period. The "Output DC Current-Limit Shutdown Voltage" is 50% of Output Voltage. If trim up or down is used protection limit will change according to output voltage setting.

Over Temperature Shutdown

The brick has a thermistor located at the hottest point inside the module. The thermal shutdown circuit is designed to turn the converter off when the temperature at the sensed location goes above the "Over Temperature Shutdown" limit. It locks itself and waits to cool off. The Converter then resumes operation automatically when the temperature of the sensed location falls below the trip point by the amount equal to the "Over Temperature Shutdown Hysteresis."

Soldering and Cleaning

Hand Soldering

1. Mounting of the brick module should not put mechanical stress on the pins and solder joints. If the brick module is to be fixed to an immovable surface, soldering should be done after the brick module is screwed to surface.
2. The tip temperature of soldering iron should not exceed 430 °C. Recommended soldering durations and soldering iron temperatures are detailed in table below.

Pin Type	Soldering Duration Range (second)	Soldering Temperature Range (°C)
Signal	3-5	330-390
+IN -IN +OUT -OUT	5-8	330-430
ON/OFF TRIM	4-6	330-410

3. Soldering the brick module for longer periods of time and at higher temperatures may result in damage to the brick module.

Wave Soldering Profile

1. Bottom side preheaters: Zone 1: 180 °C, Zone 2: 150 °C, Zone 3: 360 °C
2. Top side preheaters: Zone 1: 105-115 °C
3. Wave Temperature: 265 °C
4. Wave type: 108 mm standard laminar wave

Cleaning

1. Brick modules are not sealed, and exposure to liquids may result in damage to the brick module.
2. If PCB needs to be exposed to an aqueous wash after soldering, surface-mount or through-hole sockets are recommended for mounting the brick modules after cleaning process.

De-soldering

1. Brick modules should not be reused after de-soldering. De-soldering may cause mechanical and thermal stress that could damage the brick module. KOLT does not guarantee the reusability of brick modules after de-soldering.

Application Considerations

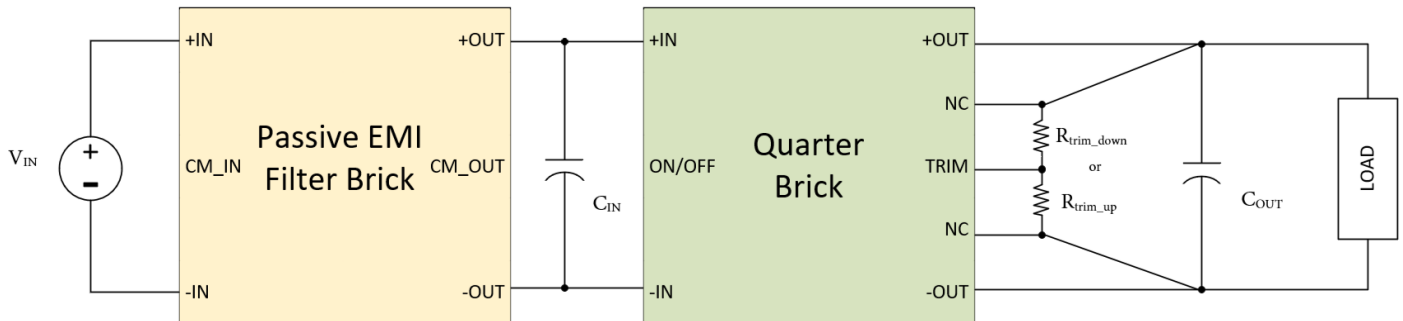

Figure 18. Typical Application

NOTE: If the output voltage is to be used in its default state, there is no need to use trim resistors.

CM_IN and CM_OUT of Passive EMI Filter should be connected to the chassis.

C_{IN}: A759KS476M1KAAE045 (47uF 80V Aluminum-Polymer Capacitor)

C_{OUT}: EEH-ZS1H181UP (180uF 50V Aluminum-Polymer Capacitor)

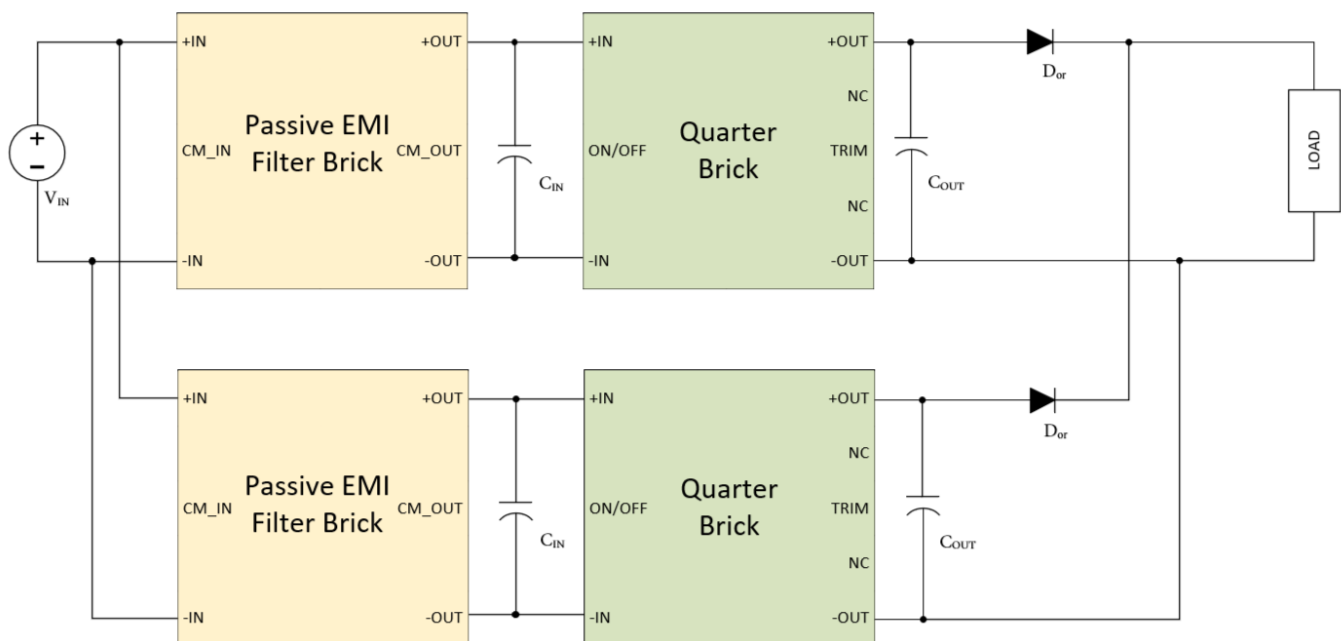

Figure 19. Recommended Application N+1 Redundant Parallel Connection

CM_IN and CM_OUT of Passive EMI Filter should be connected to the chassis.

C_{IN}: A759KS476M1KAAE045 (47uF 80V Aluminum-Polymer Capacitor)

C_{OUT}: EEH-ZS1H181UP (180uF 50V Aluminum-Polymer Capacitor)

D_{OR}: Can be either an ORing diode or ideal diode driver circuit

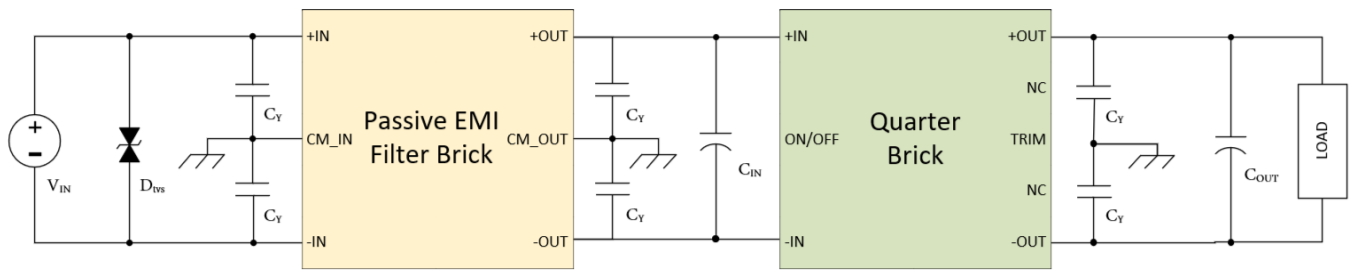

Figure 20. Recommended Application for better EMI/EMC compliance

CM_IN and CM_OUT of Passive EMI Filter should be connected to the chassis.

C_Y: CHV1206N2K0472KXT (4700 pF 2kV X7R Ceramic Capacitor)

C_{IN}: A759KS476M1KAAE045 (47uF 80V Aluminum-Polymer Capacitor)

C_{OUT}: EEH-ZS1H181UP (180uF 50V Aluminum-Polymer Capacitor)

D_{TVS}: 5.0SMDJ40CA (Bi-directional 40Vwm TVS Diode)

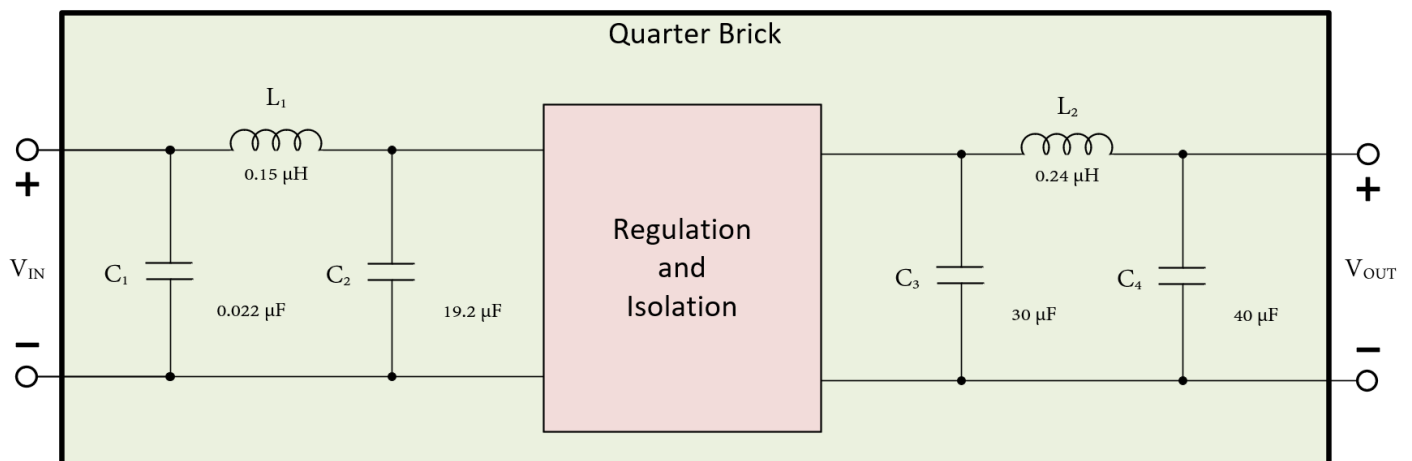
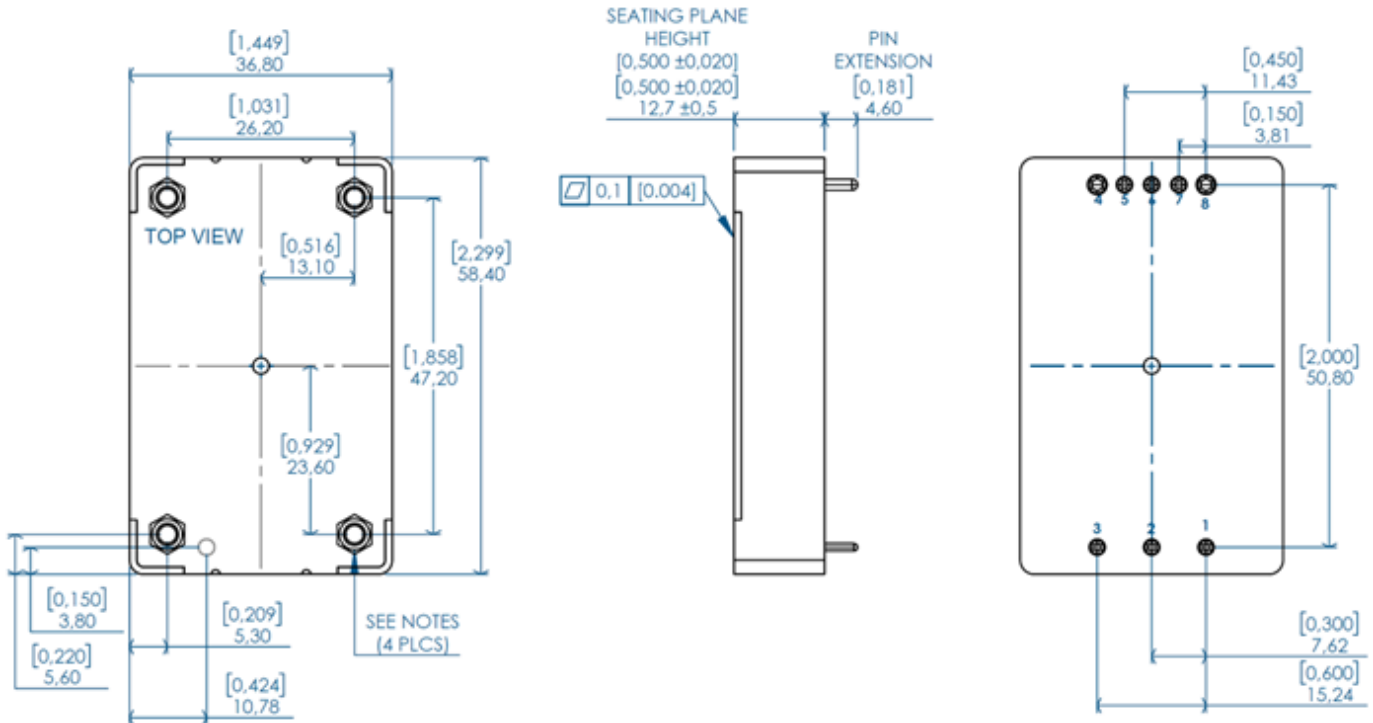

Figure 21. Internal input and output filter diagram of Quarter Brick

Mechanical Drawing – Threaded



NOTES:

- APPLIED TORQUE PER M3 SCREW 0.36Nm (3in-lb) RECOMMENDED [0.4Nm(3.5in-lb) LIMIT]. M3 SCREW SHOULD NOT TO EXCEED 3mm (0.118") DEPTH BELOW THE SURFACE OF THE BASEPLATE.
- BASEPLATE FLATNESS TOLERANCE IS 0.1mm (0.004") TIR FOR SURFACE.
- PINS 1-3 AND 5-7 ARE 1.02mm DIA. (0.040") WITH 2.03mm DIA. (0.080") STANDOFFS.
- PINS 4 AND 8 ARE 1.57mm DIA. (0.062") WITH 2.54mm DIA. (0.100") STANDOFFS.
- PINS 1-8
MATERIAL: BRASS ALLOY
FINISH: 10µ" GOLD OVER NICKEL
WEIGHT: 95.0 g (3.35 oz)
- ALL DIMENSIONS IN MILLIMETERS [inches]
- TOLERANCES: X.Xmm ±0.5mm (X.XXIN ±0.020)
X.XXmm ±0.25mm (X.XXXIN ±0.010)

Pin	Name	Function
1	+IN	Positive input voltage
2	ON/OFF	Remote on/off, referenced to -IN
3	-IN	Input return
4	-OUT	Output return
5	NC	Do not connect
6	TRIM	Output voltage trim
7	NC	Do not connect
8	+OUT	Positive output voltage



Mechanical Drawing – Flanged

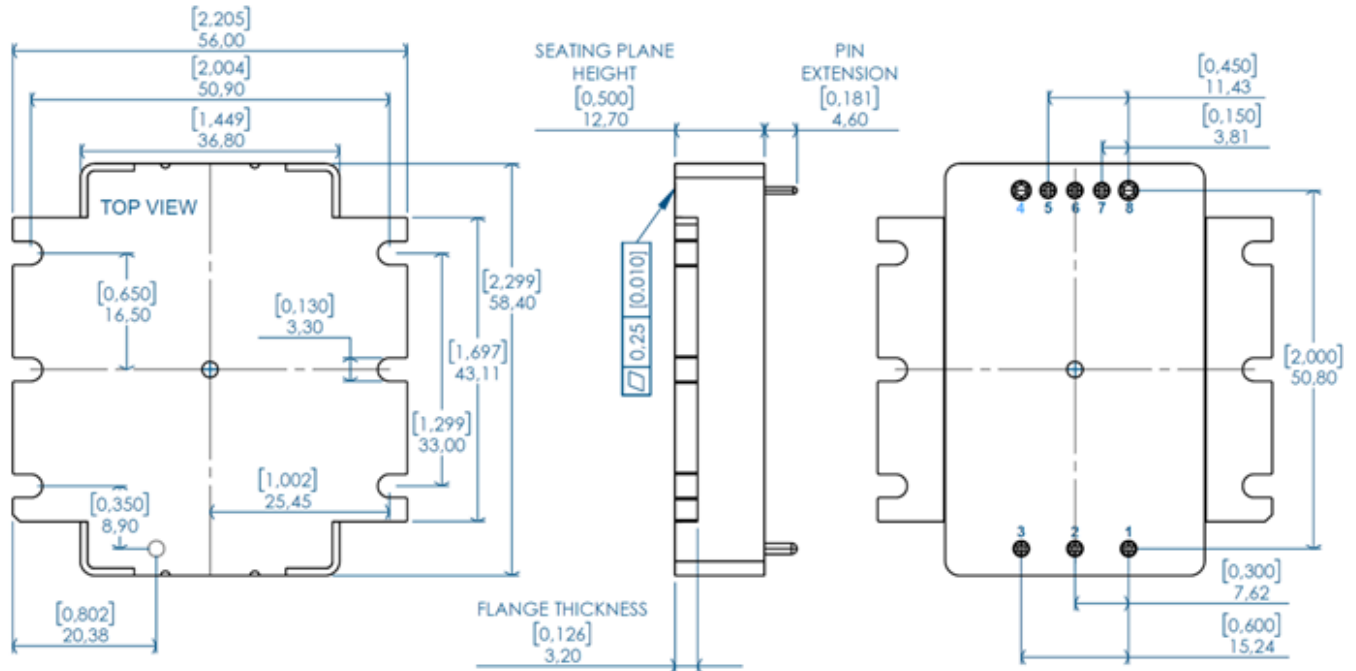

NOTES:

- APPLIED TORQUE NOT TO EXCEED 0.7Nm (6in-lb).
- BASEPLATE FLATNESS TOLERANCE IS 0.25mm (0.010") TIR FOR SURFACE.
- PINS 1-3 AND 5-7 ARE 1.02mm DIA. (0.040") WITH 2.03mm DIA. (0.080") STANDOFFS.
- PINS 4 AND 8 ARE 1.57mm DIA. (0.062") WITH 2.54mm DIA. (0.100") STANDOFFS.
- PINS 1-8
MATERIAL: BRASS ALLOY
FINISH: 10 μ " GOLD OVER NICKEL
- WEIGHT: 105.0 g (3.70 oz)
- ALL DIMENSIONS IN MILLIMETERS [inches]
- TOLERANCES: X.Xmm \pm 0.5mm (X.XXIN \pm 0.020)
X.XXmm \pm 0.25mm (X.XXXIN \pm 0.010)

Pin	Name	Function
1	+IN	Positive input voltage
2	ON/OFF	Remote on/off, referenced to -IN
3	-IN	Input return
4	-OUT	Output return
5	NC	Do not connect
6	TRIM	Output voltage trim
7	NC	Do not connect
8	+OUT	Positive output voltage



Mechanical Drawing – Threaded & Digital Communication Capable

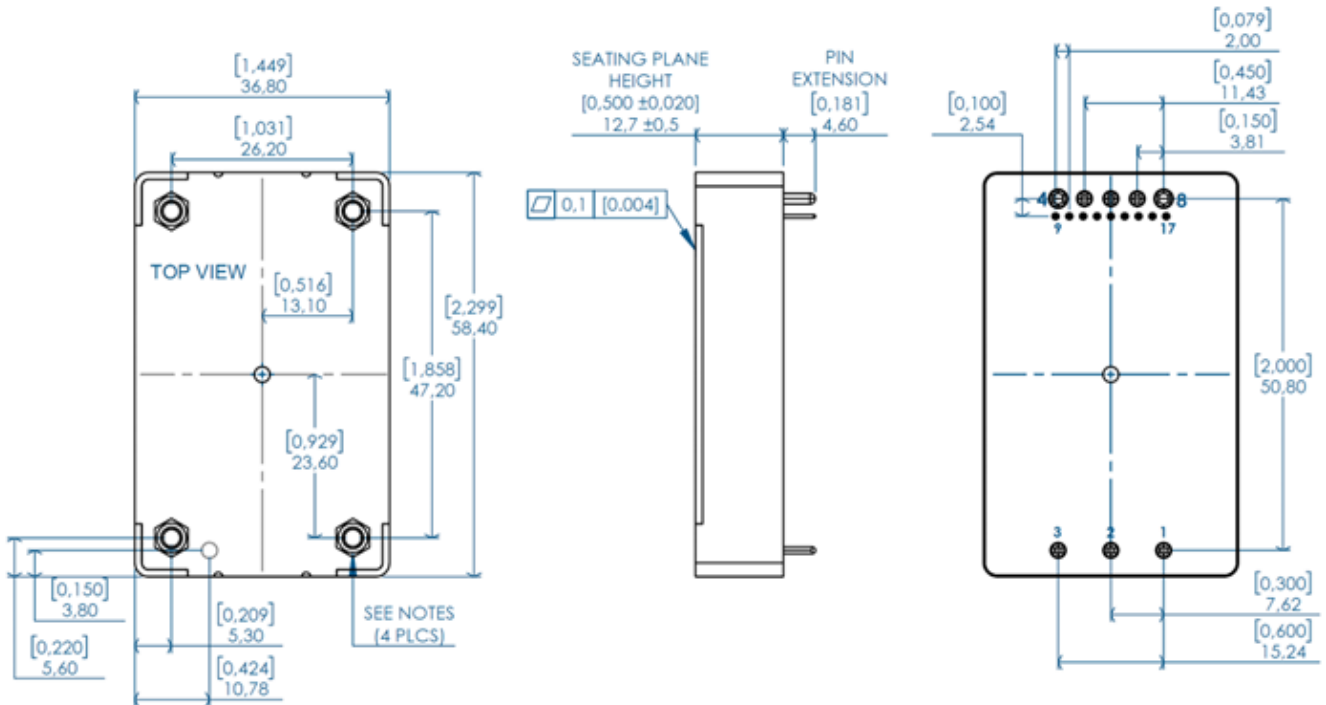

NOTES:

- APPLIED TORQUE PER 0.36Nm (3in-lb)
- RECOMMENDED [0.4Nm (3.5in-lb) LIMIT]. M3 SCREW SHOULD NOT EXCEED 3mm (0.118") DEPTH BELOW THE SURFACE OF THE BASEPLATE.
- BASEPLATE FLATNESS TOLERANCE IS 0.1mm (0.004") TIR FOR SURFACE.
- PINS 1-3 AND 5-7 ARE 1.02mm DIA. (0.040") WITH 2.03mm DIA. (0.080") STANDOFFS.
- PINS 4 AND 8 ARE 1.57mm DIA. (0.062") WITH 2.54mm DIA. (0.100") STANDOFFS.
- PM OPTION PINS 9-17 ARE 0.50mm x 0.50mm SQUARE
- PINS 1-8
MATERIAL: BRASS ALLOY
FINISH: 10µ" GOLD OVER NICKEL
- PM OPTION PINS 9-17
MATERIAL: PHOSPHOR BRONZE
FINISH: 10µ" GOLD OVER NICKEL
- WEIGHT: 95.0 g (3.35 oz)
- ALL DIMENSIONS IN MILLIMETERS [inches]
- TOLERANCES: X.Xmm ±0.5mm (X.XXIN ±0.020)
X.XXXmm ±0.25mm (X.XXXIN ±0.010)

Pin	Name	Function
1	+IN	Positive input voltage
2	ON/OFF	Remote on/off, referenced to -IN
3	-IN	Input return
4	-OUT	Output return
5	NC	Do not connect
6	TRIM	Output voltage trim
7	NC	Do not connect
8	+OUT	Positive output voltage
9*	SYNCH	Active Current Synchronization
10*	DATA-	RS485 Data-
11*	DATA+	RS485 Data+
12*	PMBUS_C2	I2C Control
13*	GND	Digital Ground
14*	PMBUS_SDA	I2C Data
15*	PMBUS_SMBALERT	I2C slave to master alert
16*	PMBUS_SCL	I2C Clock
17*	PMBUS_ADDRESS	I2C address selection

*: AVAILABLE ON PMBUS OPTION



Mechanical Drawing – Flanged & Digital Communication Capable

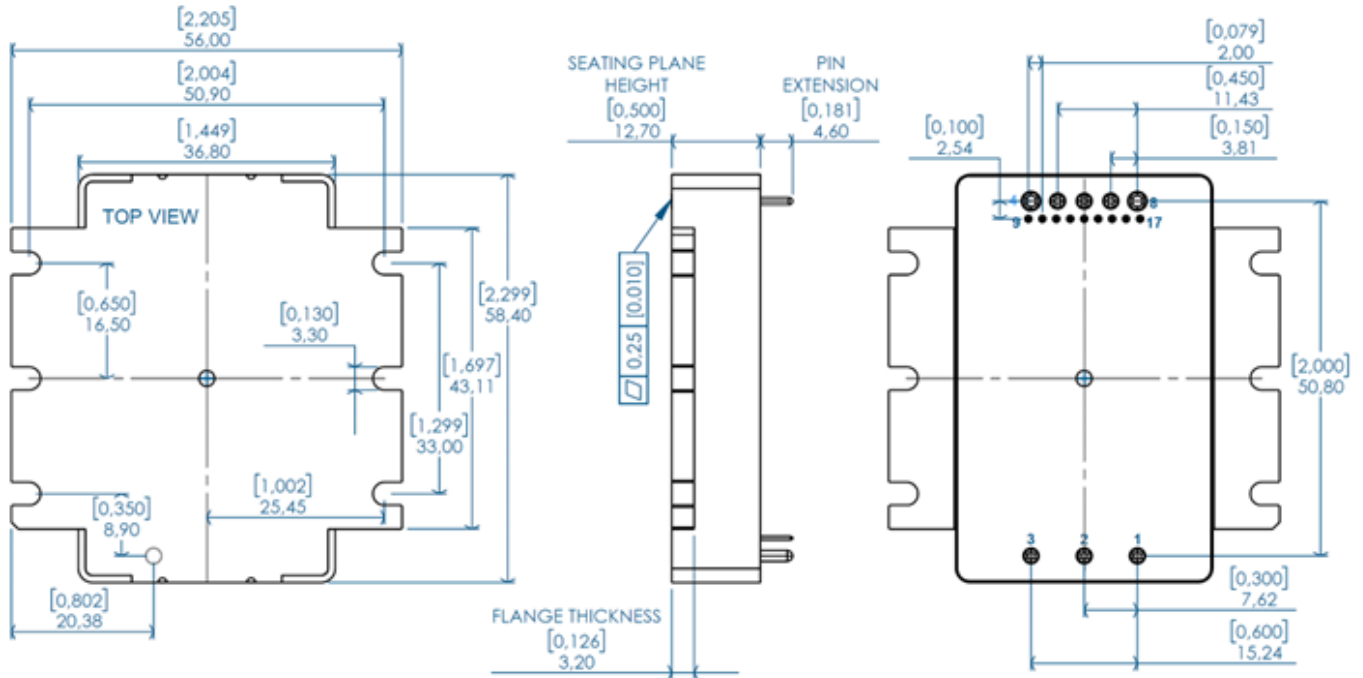

NOTES:

- APPLIED TORQUE NOT TO EXCEED 0.7Nm (6in-lb).
- BASEPLATE FLATNESS TOLERANCE IS 0.25mm (0.010") TIR FOR SURFACE.
- PINS 1-3 AND 5-7 ARE 1.02mm DIA. (0.040") WITH 2.03mm DIA. (0.080") STANDOFFS.
- PINS 4 AND 8 ARE 1.57mm DIA. (0.062") WITH 2.54mm DIA. (0.100") STANDOFFS.
- PM OPTION PINS 9-17 ARE 0.50mm x 0.50mm SQUARE PINS 1-8
- MATERIAL: BRASS ALLOY
FINISH: 10μ" GOLD OVER NICKEL
- PM OPTION PINS 9-17
MATERIAL: PHOSPHOR BRONZE
FINISH: 10μ" GOLD OVER NICKEL
- WEIGHT: 105.0 g (3.70 oz)
- ALL DIMENSIONS IN MILLIMETERS [inches]
- TOLERANCES: X.Xmm ±0.5mm (X.XXIN ±0.020)
X.XXmm ±0.25mm (X.XXXIN ±0.010)

Pin	Name	Function
1	+IN	Positive input voltage
2	ON/OFF	Remote on/off, referenced to -IN
3	-IN	Input return
4	-OUT	Output return
5	NC	Do not connect
6	TRIM	Output voltage trim
7	NC	Do not connect
8	+OUT	Positive output voltage
9*	SYNCH	Active Current Synchronization
10*	DATA-	RS485 Data-
11*	DATA+	RS485 Data+
12*	PMBUS_C2	I2C Control
13*	GND	Digital Ground
14*	PMBUS_SDA	I2C Data
15*	PMBUS_SMBALERT	I2C slave to master alert
16*	PMBUS_SCL	I2C Clock
17*	PMBUS_ADDRESS	I2C address selection

*: AVAILABLE ON PMBUS OPTION



Part Ordering Information

Family	Product Variant	Option Variant	Compliance
KEU-BM734	-002	-XXX	R: RoHS & REACH

Ordering Number	Baseplate	Communication	Current Sharing	RoHS (Note*)
KEU-BM734-002-001	Threaded	No communication capability, comm. pins are absent.	Not Available	RoHS 5/6 (Pb above limit)*
KEU-BM734-002-002	Threaded	No communication capability, comm. pins are absent.	Droop Sharing	RoHS 5/6 (Pb above limit)*
KEU-BM734-002-003	Threaded	With digital communication capability	Not Available	RoHS 5/6 (Pb above limit)*
KEU-BM734-002-004	Threaded	With digital communication capability	Droop Sharing	RoHS 5/6 (Pb above limit)*
KEU-BM734-002-005	Flanged	No communication capability, comm. pins are absent.	Not Available	RoHS 5/6 (Pb above limit)*
KEU-BM734-002-006	Flanged	No communication capability, comm. pins are absent.	Droop Sharing	RoHS 5/6 (Pb above limit)*
KEU-BM734-002-007	Flanged	With digital communication capability	Not Available	RoHS 5/6 (Pb above limit)*
KEU-BM734-002-008	Flanged	With digital communication capability	Droop Sharing	RoHS 5/6 (Pb above limit)*
KEU-BM734-002-001R	Threaded	No communication capability, comm. pins are absent.	Not Available	RoHS-3 & REACH compliant
KEU-BM734-002-002R	Threaded	No communication capability, comm. pins are absent.	Droop Sharing	RoHS-3 & REACH compliant
KEU-BM734-002-003R	Threaded	With digital communication capability	Not Available	RoHS-3 & REACH compliant
KEU-BM734-002-004R	Threaded	With digital communication capability	Droop Sharing	RoHS-3 & REACH compliant
KEU-BM734-002-005R	Flanged	No communication capability, comm. pins are absent.	Not Available	RoHS-3 & REACH compliant
KEU-BM734-002-006R	Flanged	No communication capability, comm. pins are absent.	Droop Sharing	RoHS-3 & REACH compliant
KEU-BM734-002-007R	Flanged	With digital communication capability	Not Available	RoHS-3 & REACH compliant
KEU-BM734-002-008R	Flanged	With digital communication capability	Droop Sharing	RoHS-3 & REACH compliant

RoHS & REACH Compliance*

By default, KOLT products are manufactured using SnPb solder for high-reliability applications and therefore are **not** compliant with EU RoHS Directive 2011/65/EU (as amended by (EU) 2015/863). These products meet RoHS requirements for all substances except lead (Pb). **These products are NOT CE marked due to SnPb solder.**

A **lead-free** build that meets RoHS-3 requirements and is designed to be REACH compliant is available by adding the “-R” suffix to the part number. **Only these products are CE marked.**

Revision History

Document Number	Revision	Date	Description	Page Number(s)
110262	01	20.03.2025	Initial Release	-
110262	02	30.07.2025	Part Number Updated	-
110262	03	11.03.2026	CE marking updated. The technical details have been updated.	-

Contact Us

KOLT Türkiye

salesturkiye@koltpower.com

KOLT Muhendislik A.S.

Saray OSB, G2 Cd. No:9
Kahramankazan, Ankara 06980

Türkiye

www.kolt.com.tr**KOLT Europe**

saleseurope@koltpower.com

KOLT Power Ltd.

Fareham Innovation Centre, Merlin House, 4 Meteor Way,
Daedalus Drive, Lee-On-Solent, Fareham, PO13 9FU

United Kingdom

www.koltpower.com

The information provided in this datasheet is believed to be accurate and reliable. However, KOLT assumes no responsibility for any consequences arising from its use, nor for any infringement of patents or other rights of third parties that may result from its use. These products are sold only under KOLT's general terms and conditions of sale, unless otherwise specified in writing. Specifications are subject to change without notice. All rights reserved.