

MODEL NO.:

2412-01SF

NOTE: Information herein is believed by Southwest Microwave, Inc. to be accurate. However, Southwest Microwave assumes no responsibility for any omissions or errors or inaccuracies for its use or for any infringements of patents or other rights of third parties that may result from its use. Data is intended for informational purpose only and does not constitute a contract of sale or any express or implied warranty, including any warranty of merchant ability or fitness for a particular purpose.

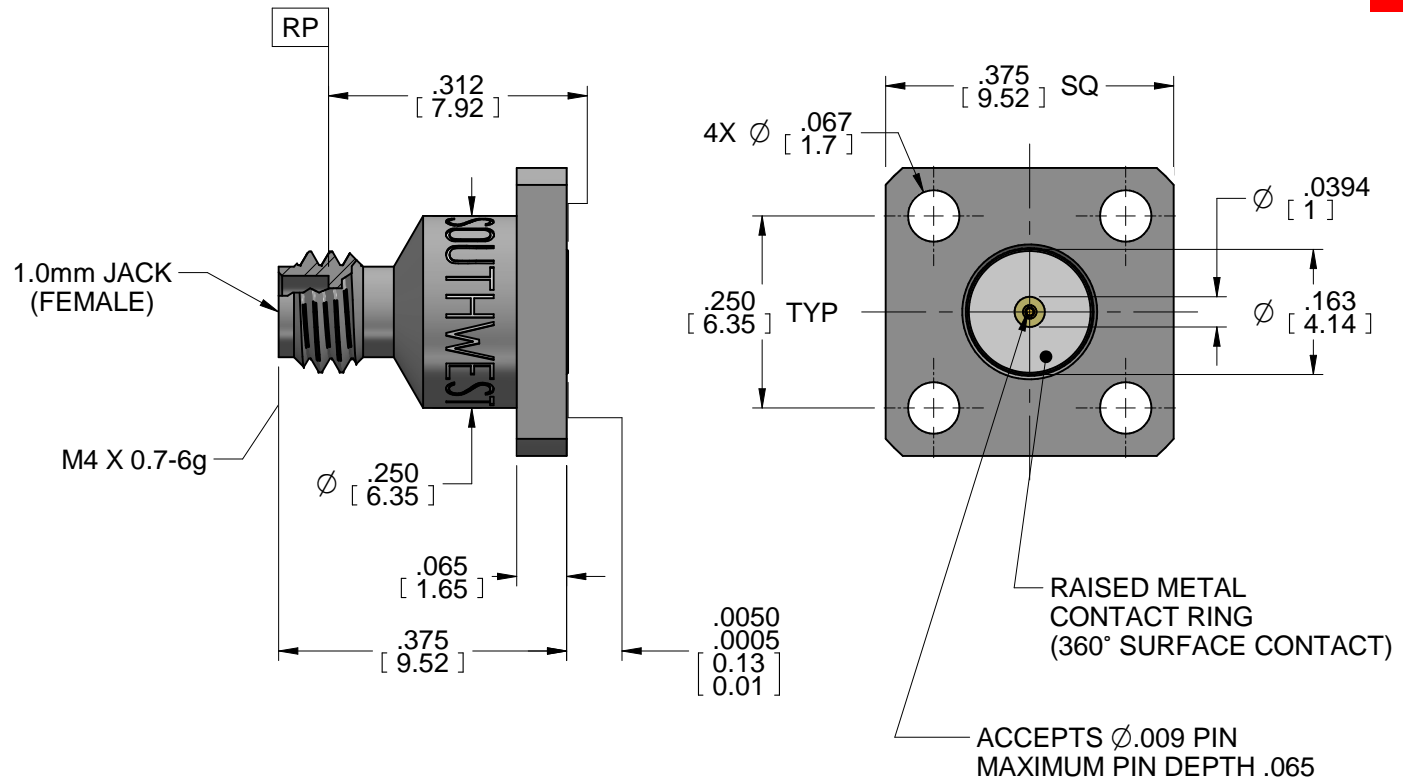
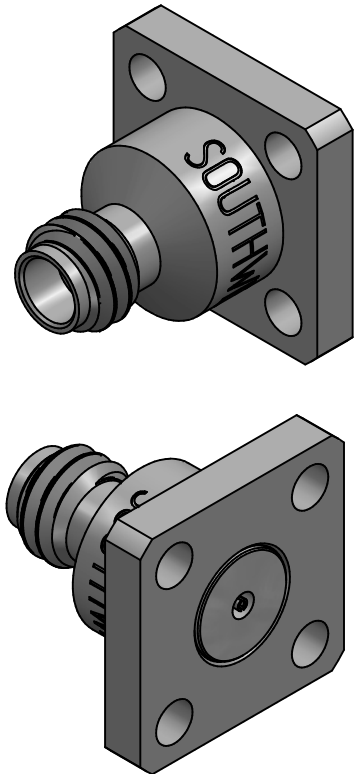

**DOCUMENT
CONTROL
JUL 20 2023**

HOUSING:	STEEL, CRES ALLOY UNS-30300 PER ASTM A582 PASSIVATED PER ASTM A967
CONTACT:	BeCu UNS-C17300 PER ASTM B196 GOLD PLATE PER ASTM B488
CAPTURE BEAD:	ULTEM 1000 PER ASTM D5205
ITEM	MATERIAL & FINISH

1. ALL DIMENSIONS ARE IN INCHES. ALL ANGLES ARE IN DEGREES.
DIMENSIONS SHOWN IN BRACKETS [XXX] ARE IN MILLIMETERS.

NOTES: UNLESS OTHERWISE SPECIFIED.

REV B	ECN 927	REV BY. JAC	APRVD. DE	DATE: 07/20/23	TITLE MODEL 2412-01SF 1.0mm J 4H .375SQ (.009)			
 Southwest Microwave, Inc. 9055 South McKemy Street Tempe, Arizona 85284-2946 Telephone (480) 783-0201 Fax (480) 783-0360					DRN BY: DE	DATE: 05/20/14	DWG. NO. 79W61584	REV. B
					SHEET: 1 OF 1			