

MODEL No.:

52070-006P

NOTE: Information herein is believed by Southwest Microwave, Inc. to be accurate. However, Southwest Microwave assumes no responsibility for any omissions or errors or inaccuracies for its use or for any infringements of patents or other rights of third parties that may result from its use. Data is intended for informational purpose only and does not constitute a contract of sale or any express or implied warranty, including any warranty of merchant ability or fitness for a particular purpose.

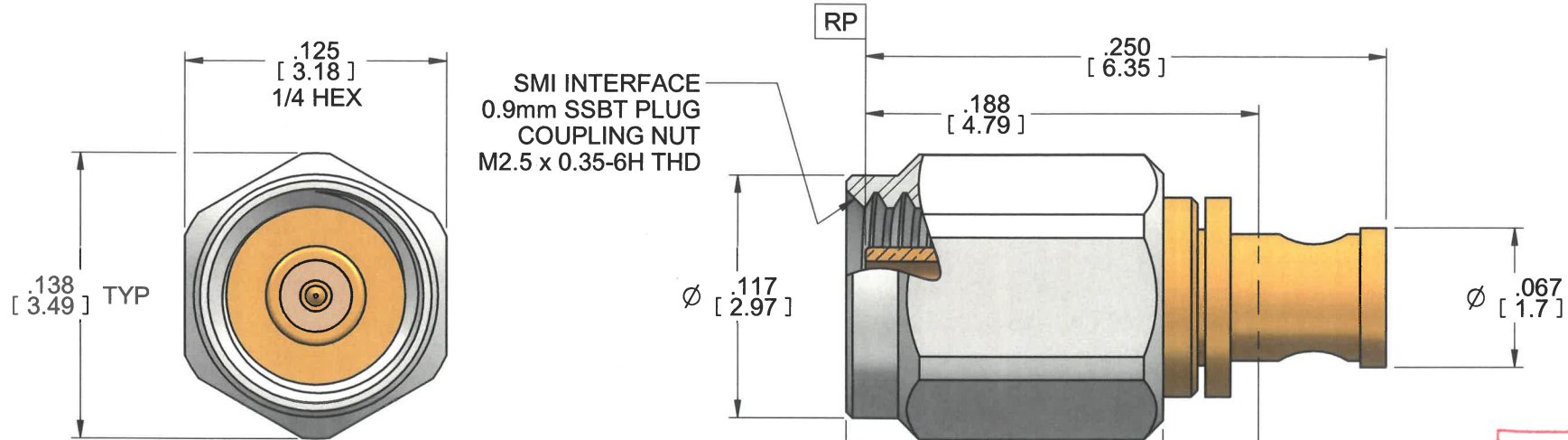

DOCUMENT CONTROL
NOV 16 2022

COUPLING NUT:	STEEL CRES ALLOY UNS-S17400 PER ASTM A564, PASSIVATED PER ASTM A967
CONTACT:	BeCu UNS-C17300 PER ASTM B196 GOLD PLATE PER ASTM B488
BODY:	BeCu UNS-C17300 PER ASTM B196 GOLD PLATE PER MIL-DTL-45204
RETAINING RING:	BeCu UNS-C17300 PER ASTM B196
CAPTURE BEAD:	PEEK HT
ITEM	MATERIAL & FINISH

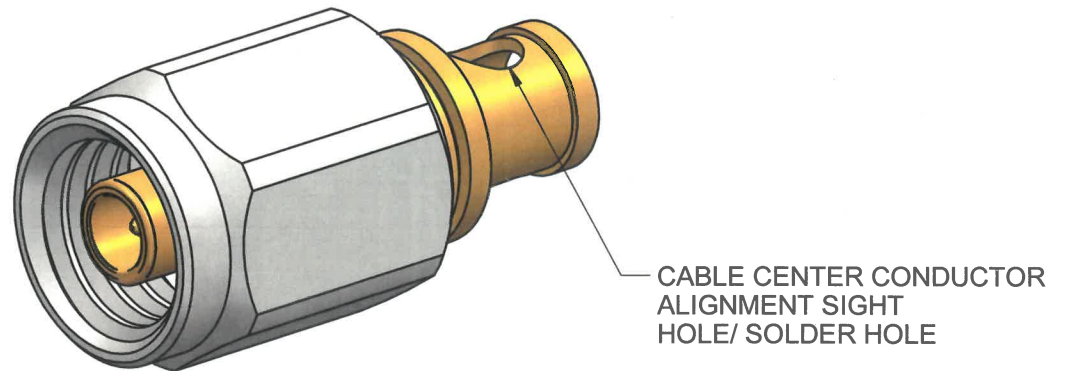

- PERFORMANCE IS DEPENDENT UPON THE SPECIFIC CABLE SELECTED AND THIRD-PARTY CABLE PREPARATION BEYOND CONTROL OF SOUTHWEST MICROWAVE.
- CABLE TERMINATION INSTRUCTIONS PER SMI DOCUMENT 91BT60541.
- CONNECTOR DESIGN IS COMPATIBLE WITH CURRENT MATERIAL PROCESS REQUIREMENTS FOR RoHS AND WEEE PER EUROPEAN COMMUNITY DIRECTIVE 2002/95/EC.
- ALL DIMENSIONS ARE IN INCHES. ALL ANGLES ARE IN DEGREES. DIMENSIONS SHOWN IN BRACKETS [XXX] ARE IN MILLIMETERS.

NOTES: UNLESS OTHERWISE SPECIFIED.

REV D	ECN 854	REV BY KS	APRVD. <i>DE</i>	DATE: 11/15/22	TITLE	MODEL: 52070-006P 0.9mm SSBT P DS 047 CBL	
 <p>SOUTHWEST MICROWAVE</p>		Southwest Microwave, Inc. 9055 South McKerny Street Tempe, Arizona 85284-2946 Telephone (480) 783-0201 Fax (480) 783-0360			DRN BY: EJO	DATE: 10/18/13	DWG. NO. 79BT61193
					SCALE: 12:1		
					SHEET: 1 OF 1		