

Features & Benefits

- Isolated DC/DC Rugged Module
- Galvanic isolation
- Up to 300 W, 10.7 A continuous
- 91.3% peak efficiency
- Continuous input voltage range 16 – 40 V
- Input under/over voltage protection
- Output over voltage protection
- Output over current protection
- Output short-circuit protection
- Thermal shutdown
- ON/OFF Control

Typical Applications

- Defense
- Aerospace
- Communications Systems
- Medical

Product Ratings	
$V_{IN_NOM} = 28\text{ V}$	$P_{OUT} = 300\text{ W}$
$V_{IN_MIN} = 16\text{ V}$	$V_{OUT_NOM} = 28\text{ V}$
$V_{IN_MAX} = 40\text{ V}$	$I_{OUT_MAX} = 12\text{ A}$

Product Description

KMRM02-DC28WE-P300-DC28-CM is a 300W DC/DC converter in rugged module converter that operates from nominal 28 V input and generates 28 V isolated output. It is designed to meet MIL-STD-461 EMI requirements with the built-in KRFL01 EMI filter module and has superior noise and ripple performance. Converter is fully protected to operate reliably under all kinds of disturbances. Casing is creatively designed to provide efficient cooling to facilitate reliable operation at 100 °C base plate temperature.

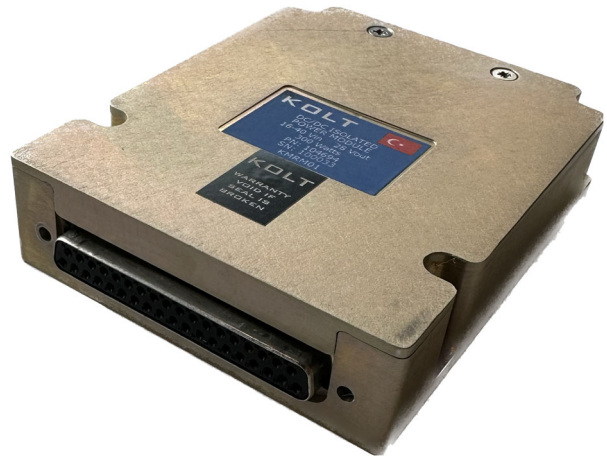

Size:

100 × 80 × 23.4 mm

Weight:

340 g

Electrical Characteristics

All data are obtained at nominal line and load unless otherwise specified.

Module Input Specifications

Parameters	Min	Typ	Max	Unit	Notes
Operating Input Voltage	16	28	40	V	
Under Voltage Turn On		16.1		V	
Under Voltage Turn Off		15.1		V	
Over Voltage Turn Off		41.1		V	
Over Voltage Turn On		37.3		V	
Disabled Input Current			1	mA	No-load
No Load Input Current	279		318	mA	No-load

Module Output Specifications

Parameters	Min	Typ	Max	Unit	Notes
Output Voltage		28		V	
Output Voltage Set Point			±1	%	Full load, 25 °C, nominal input
Rated Output Power			300	W	
Line Regulation			±0.2	%	From low line to high line at full load
Load Regulation			±0.2	%	From no load to full load at nominal input
Peak Efficiency			91.3	%	Full load
Output Ripple		30	40	mV	Full load, nominal input
Output Current	0		10.7	A	
Output Current Limit			12	A	Fully electronic against over-load
Output Voltage Trim Range	-40		+10	%	
Output Over Voltage Protection			33.6	V	

Feature Characteristics

Parameters	Min	Typ	Max	Unit	Notes
Switching Frequency		150		kHz	
Over Temperature Shutdown Trip Point		110		°C	Average PCB temperature
Over Temperature Recovery		100		°C	

Absolute Maximum Ratings

The absolute maximum ratings below are stress ratings only. Operation at or beyond these maximum ratings may cause permanent damage to the device.

Parameters	Min	Typ	Max	Unit	Notes
Input Voltage					
Non-Operating Input Voltage	-1		60	V	
Operating Input Voltage (Continuous)			40	V	
Operating Input Voltage (Transient)			100	V	100ms max.
Operating Temperature	-40		+100	°C	Baseplate temperature
Storage Temperature	-40		+125	°C	

Application Characteristics

Measurements are taken at nominal conditions (25 °C).

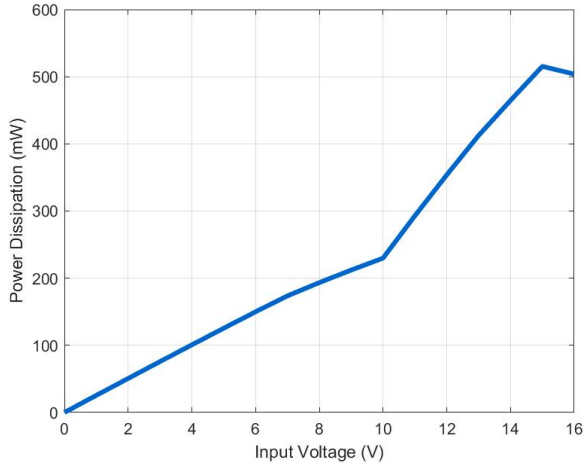

Figure 1. Disabled power dissipation versus input voltage

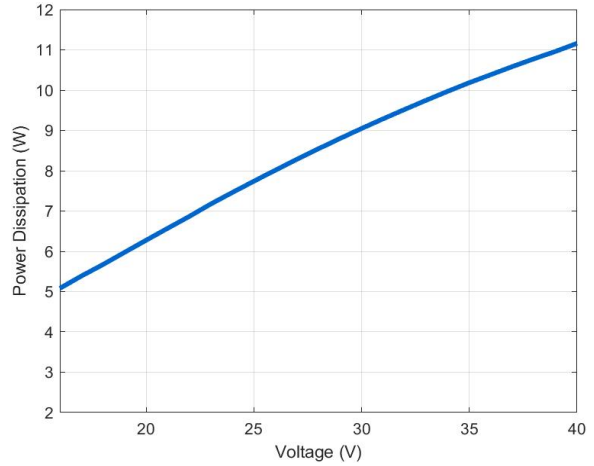

Figure 2. Enabled power dissipation versus input voltage

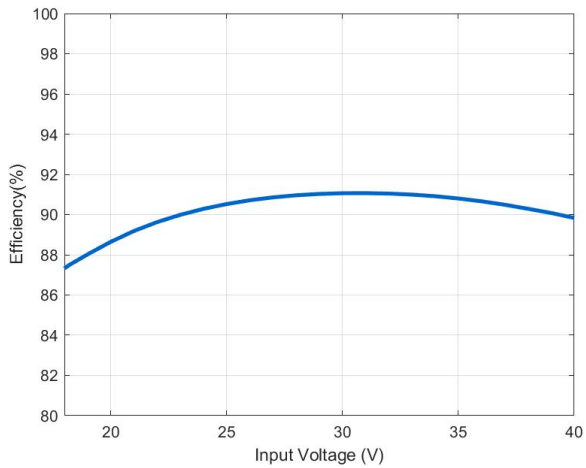

Figure 3. Full load efficiency versus input voltage

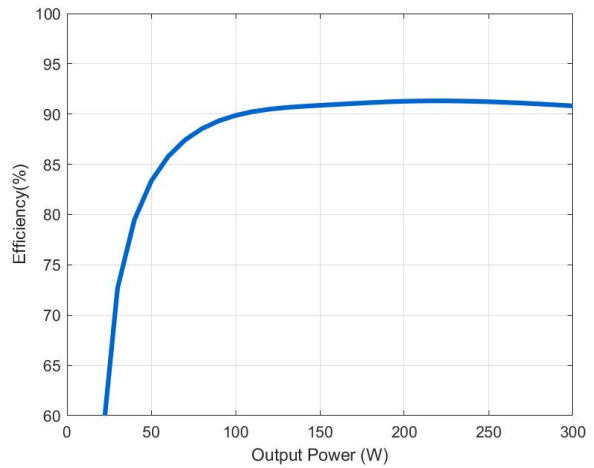

Figure 4. Efficiency versus output power at nominal input voltage (36 V)

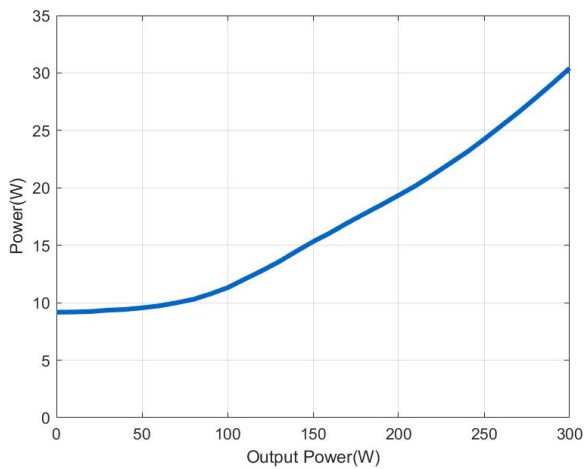
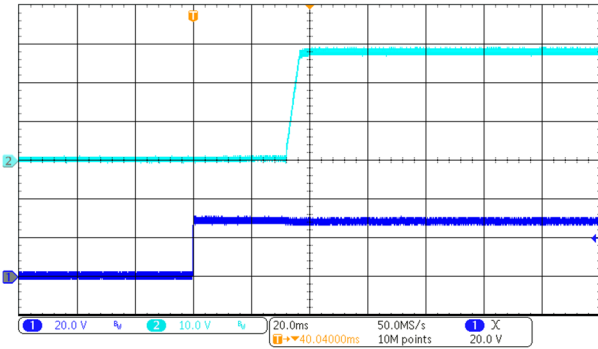
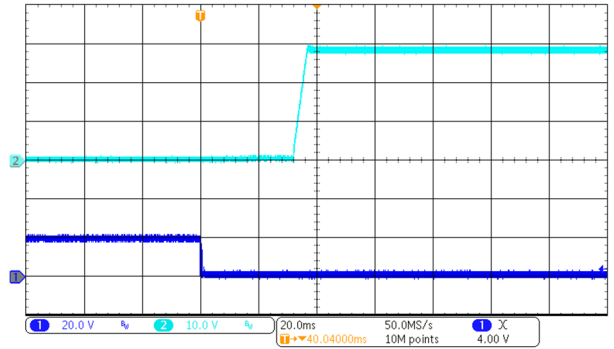

Figure 5. Power dissipation versus output power at nominal input voltage (36 V)



Output voltage (blue) (10 V/div) Time base : 20 ms/div
Startup initiation signal (navyblue) (20 V/div)

Figure 6. Converter startup waveforms



Output voltage (blue) (10 V/div) Time base : 20 ms/div
On/Off pin state (navyblue) (20 V/div)

Figure 7. Turn on transient at full resistive load

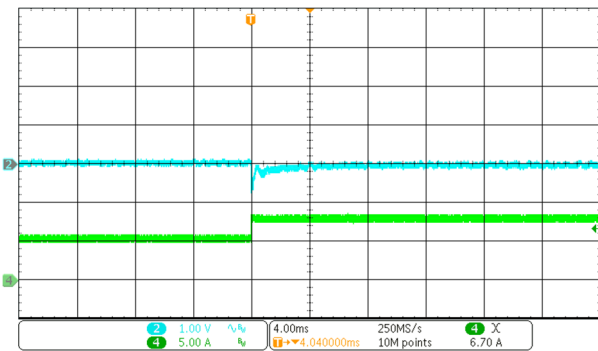

Output voltage (blue) (1 V/div) Time base : 4 ms/div
Output current (green) (5 A/div)

Figure 8. Load transient response: from 50% to 75%

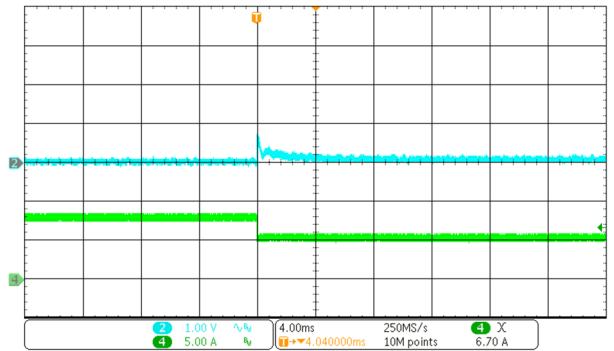

Output voltage (blue) (1 V/div) Time base : 4 ms/div
Output current (green) (5 A/div)

Figure 9. Load transient response: from 75% to 50%

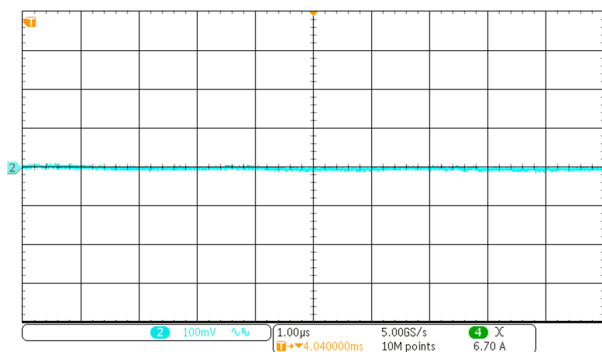

Output voltage ripple (100 mV/div) Time base : 1 μs/div

Figure 10. Output voltage ripple at nominal input voltage and full load current (10.7 A).

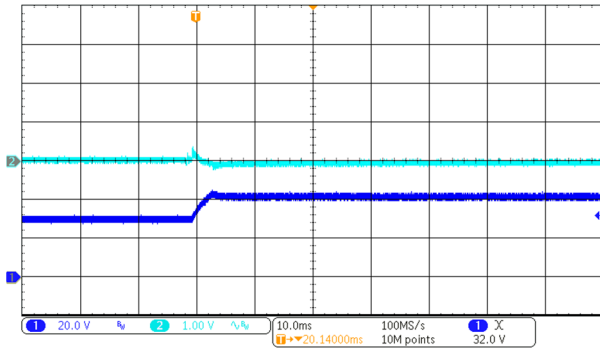

Output voltage (blue) (1 V/div) Time base : 10 ms/div
Input voltage (navyblue) (20 V/div)

Figure 11. Line (Vin) transient response: from 28 V to 40 V at full resistive load.

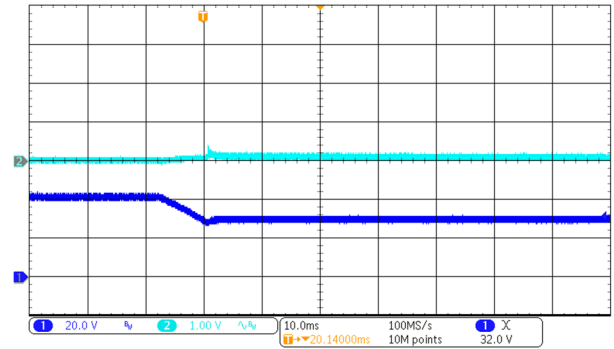

Output voltage (blue) (1 V/div) Time base: 10 ms/div
Input voltage (navyblue) (20 V/div)

Figure 12. Line (Vin) transient response: from 40 V to 28 V at full resistive load.

Basic Operation and Features

ON/OFF

The ON/OFF input, Pin 23, allows the user to control the ON and OFF states of the converter. This input is referenced to the return terminal of the input bus, -IN. The ON/OFF signal is active low. If it is pulled down to ground, converter goes into ON state. Moreover, the ON/OFF function allows the product to be turned on/off by an external device like a semiconductor or a mechanical switch.

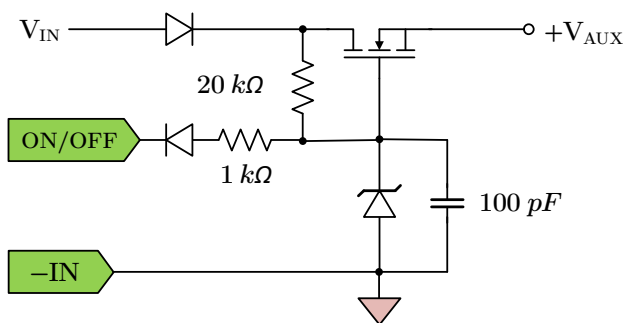

Figure A. Driving ON/OFF Pin

Protection Features

Input Under Voltage Lockout

Converter starts operating when input voltage is raised above “Under Voltage Turn On” limit. Once on, turn off is initiated when input falls below “Under Voltage Turn Off” limit. The associated limits are given in “Module Input Specifications” Table.

Input Over Voltage Lockout

Converter protects itself by ceasing operation when input goes above “Over Voltage Turn Off” limit. It resumes operation when input falls below “Over Voltage Turn On” limit. The associated limits are given in “Module Input Specifications” Table.

Output Current Limit

If the output current exceeds the “Output Current Limit” value, the converter will immediately stop operating. The control waits 250 ms and resets fault status automatically and resumes operation with soft start. If the fault condition is still persisting, its shuts off again. This sequence is repeated five times. If the fault is cleared by that time, the normal operation continues, otherwise it shuts itself off and waits for the hard reset.

Output Over Voltage Lockout

The default output OVP limit is set to 25% above the nominal output voltage. When detected, protection control responds immediately by shutting down the converter and disabling the outputs. Start sequence is similar to the output current limit case.

Over Temperature Shutdown

The brick has a thermistor located next to the hottest point, the transformer. The thermal shutdown circuit is designed to turn the converter off when the temperature at the sensed location goes above “Over Temperature Shutdown” limit. Converter resumes operation when the temperature of the sensed location falls by the amount equal to the “Over Temperature Shutdown Restart Window.”

Short Circuit Protection

The short circuit condition is an extreme case of the Output Current Limit condition. When the fast rise of the current during a short circuit condition is detected by the dedicated control, the outputs of the converter are disabled immediately. The sequence of operation after a short circuit detection is similar to hiccup concept described in “Output Current Limit” section.

Mechanical Drawing

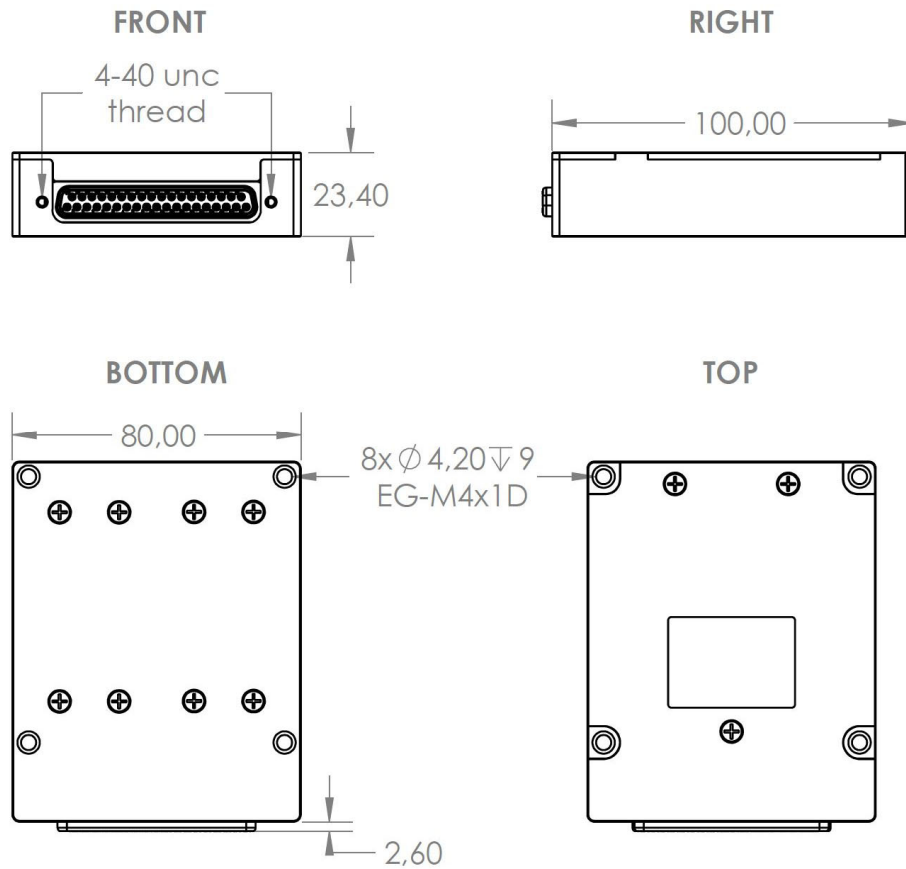

Output Connector: 164A17969X					
Pin	Signal	Pin	Signal	Pin	Signal
1	VIN	14	VOUT	27	-SNS
2	-VIN	15	-VOUT	28	NC
3	VIN	16	VOUT	29	-VOUT
4	CHASIS	17	-VOUT	30	-VOUT
5	NC	18	VOUT	31	VOUT
6	NC	19	VOUT	32	-VOUT
7	NC	20	-VIN	33	VOUT
8	TRIM	21	VIN	34	-VOUT
9	NC	22	-VIN	35	VOUT
10	NC	23	ON_OFF	36	-VOUT
11	-VOUT	24	NC	37	VOUT
12	VOUT	25	NC		
13	-VOUT	26	+SNS		

#NOTES

1. CASE MATERIAL: 6061 T6 ALUMINUM
2. RECOMMENDED TORQUE VALUE: 2.5 Nm

Ordering Information

Family	Input Voltage	Power	Output Voltage	Package
KMRM01	DC28: 16-40	P300: 300 W	DC28: 28 V	CM: Custom Module

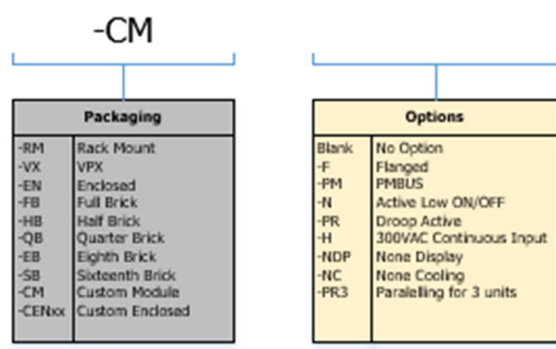
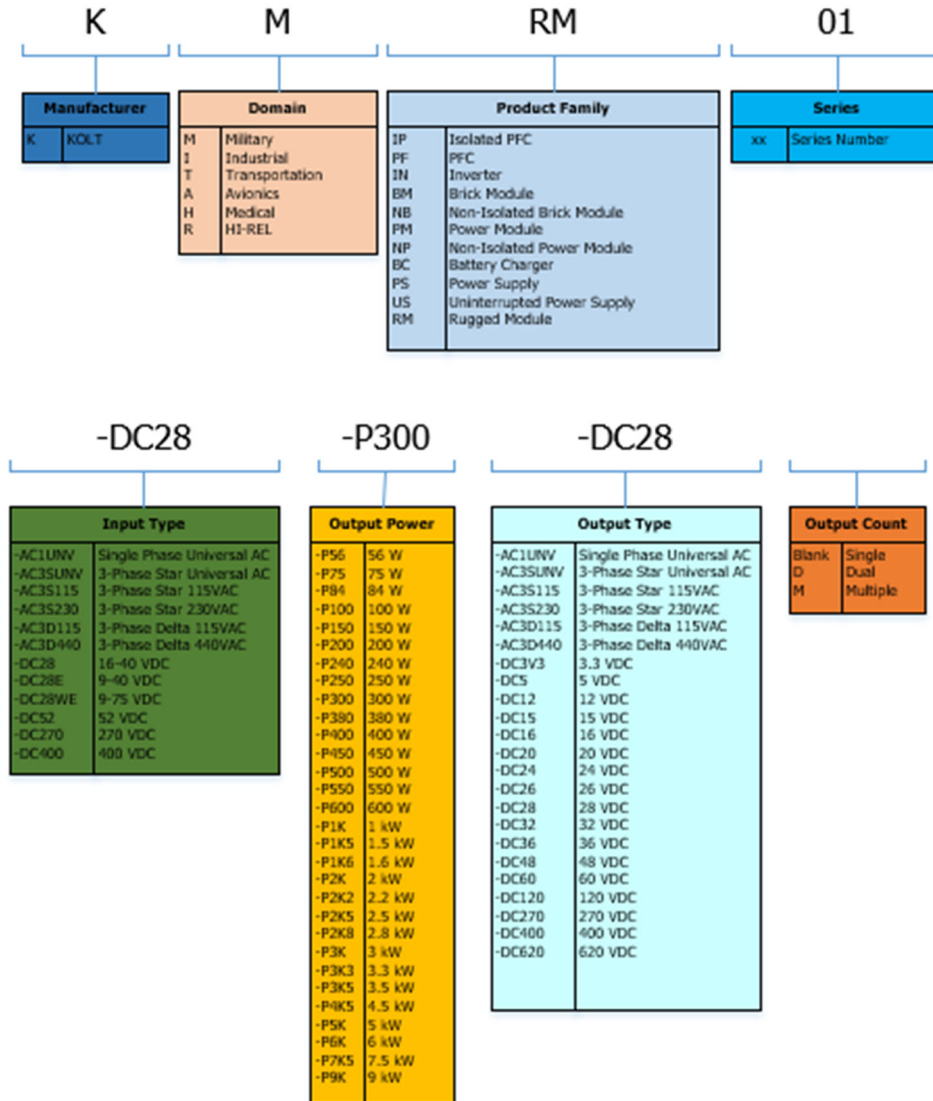

Not all combinations make valid part numbers, please contact KOLT for availability.

Revision History

Revision	Date	Description	Page Number(s)
A-PC1	17.03.2023	Initial Release	-