

### Features & Benefits

- Non-isolated, regulated DC-DC buck-boost converter
- Up to 140 W, 7 A continuous
- 97.1% peak efficiency
- Input voltage range 18.3 – 36 V<sub>DC</sub>
- Overcurrent protection
- Short-Circuit protection
- Under voltage protection
- Conformal coated

### Typical Applications

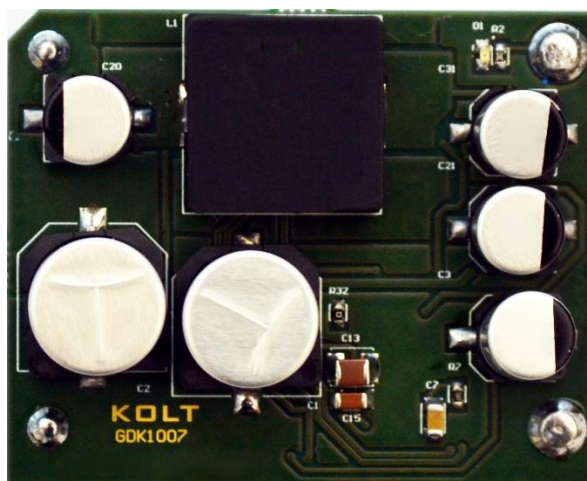
- Defense
- Aerospace
- Communications Systems
- Medical

Product Ratings	
VIN = 28 V (18.3 – 36 V)	POUT = 140 W
VOU = 20 V	IOU = 7 A

### Product Description

GDK1007-20 is a 140 W DC/DC non-isolated point-of-load converter that operates at nominal 28 VDC input and generates 20 VDC output.

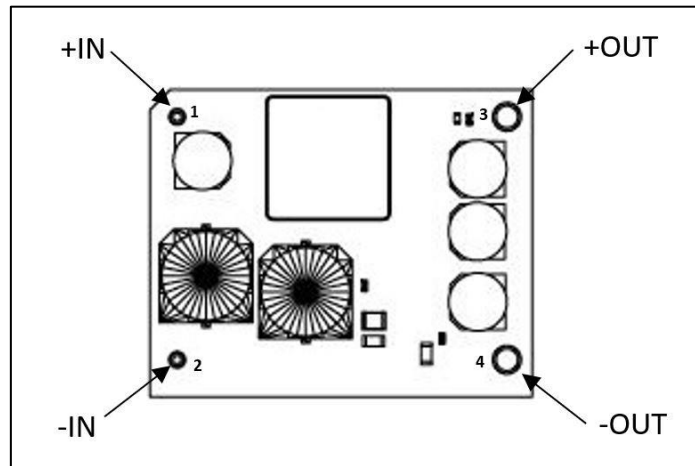
GDK1007-20 has a synchronous buck-boost converter topology and due to this, it has a high efficiency across all line and load conditions.



Size:

56 x 45 x 18.75 mm

### Pin Configuration



### Pin Descriptions

Power Pins		
Pin Number	Signal Name	Type
1	+ IN	Positive input power terminal
2	- IN	Negative input power terminal
3	+ OUT	Positive output power terminal
4	- OUT	Negative output power terminal

### Absolute Maximum Ratings

The absolute maximum ratings below are stress ratings only. Operation at or beyond these maximum ratings may cause permanent damage to the device.

Parameter	Comments	Min	Max	Unit
Input Voltage	DC voltage	0	50	VDC
Operating Temperature		-40	70	°C
Storage Temperature		-40	90	°C

### Electrical Characteristics

All data at nominal line and nominal load unless otherwise specified.

#### Module Input Specifications

Power Input Specifications					
Parameter	Min	Typ	Max	Unit	Notes
Operating Input Voltage	18.6	28	36	VDC	
Under voltage Turn-on	18.3	18.5	18.7	VDC	
Under voltage Turn-off	15	15.4	16	VDC	
No-Load Specifications					
Disabled Power Dissipation			12.7	mW	
Enabled Power Dissipation	0.88		1.45	W	

#### Module Output Specifications

Parameter	Min	Typ	Max	Unit	Notes
Output Voltage	19.90	20.00	20.10	VDC	
Output Voltage Set Point			±0.5	%	Full load, 25 °C, Nominal Input
Rated Output Power			140	W	
Line Regulation		±0.005	±0.02	%	Low line to high line, Full load
Efficiency	95.63	96.94	96.96	%	Full load
Ripple and Noise		100	150	mV	Full load, Nominal Input
Load Regulation		±0.005	±0.02	%	Low line to high line, Full load
Load Current			7	A	
Current Limit			16.66	A	

## General Characteristics

Attribute	Symbol	Conditions/Notes	Min	Typ	Max	Unit
<b>Mechanical</b>						
Length	L			56		mm
Width	W			45		mm
Height	H			22.75		mm
Weight	W			40.2		g
Pin Material		Brass				
Pin Finish		Tin over Nickel	5		40	µm
<b>Thermal</b>						
Operating Temperature	Top		-40		70	°C
Storage Temperature	Tst		-40		90	°C
Board Max. Component Temp. @ 25 °C					53	°C
<b>Safety</b>						
MTBF		MIL-HDBK-217Plus Parts Count-25°C Ground Benign, Stationary, Indoors/Computer		TBD		MHrs
<b>Assembly</b>						
Pin Soldering Temperature	°C	<4 sec., hand soldering		390		°C

### Application Characteristics

Measurements are taken at nominal conditions (25 °C).

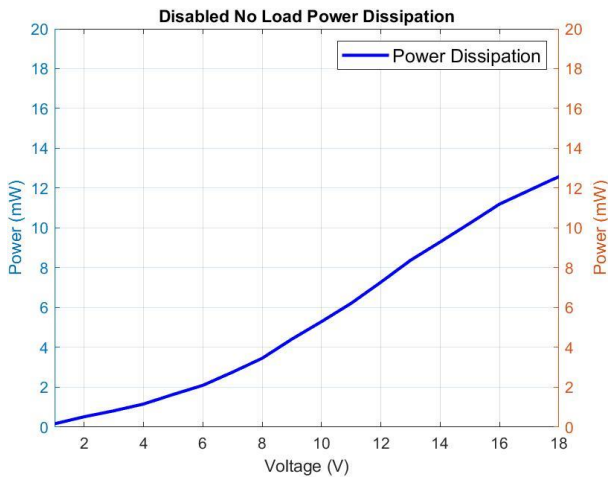


Figure 1. Disabled Power Dissipation vs  $V_{IN}$

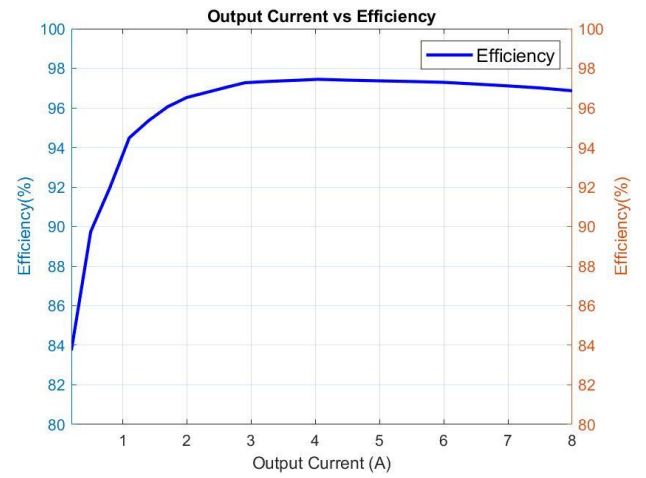


Figure 4. Efficiency vs Load

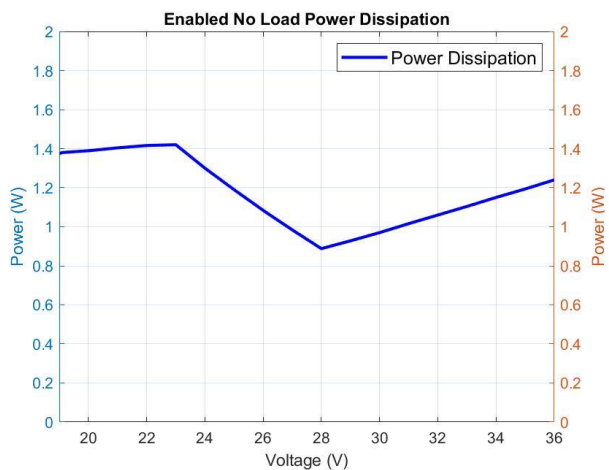


Figure 2. Enabled Power Dissipation vs  $V_{IN}$

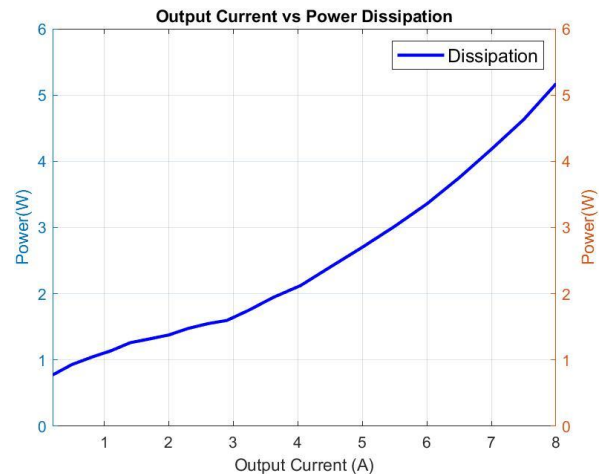


Figure 5. Power Dissipation vs Load

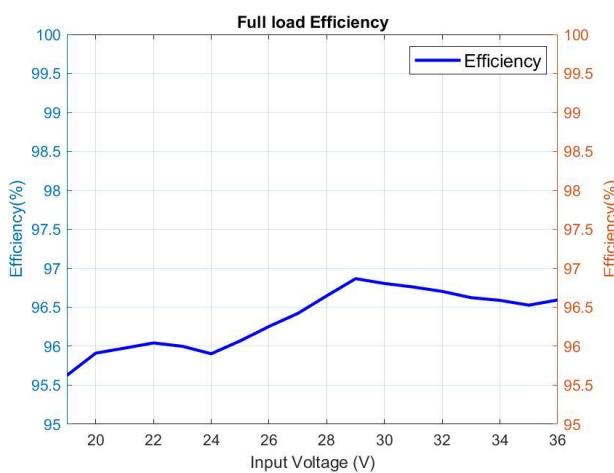


Figure 3. Full Load Efficiency vs  $V_{IN}$

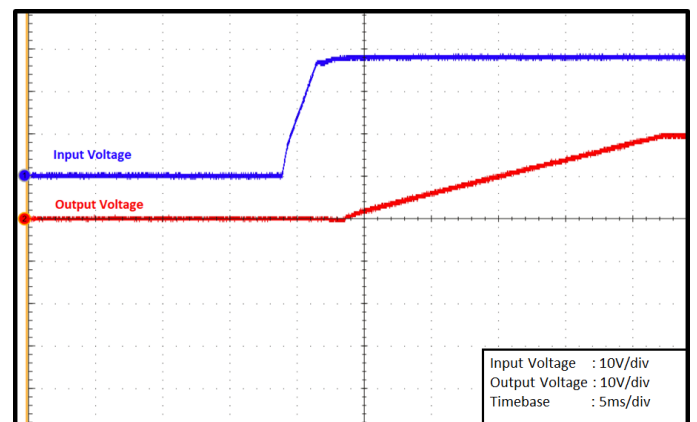


Figure 6. Input Voltage Start up No Load

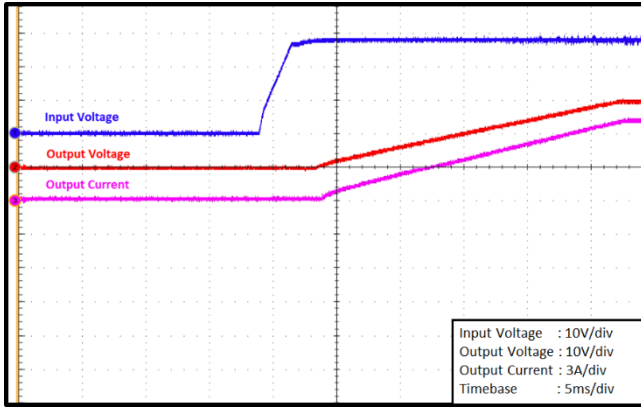


Figure 7. Input Voltage Start up Full Load

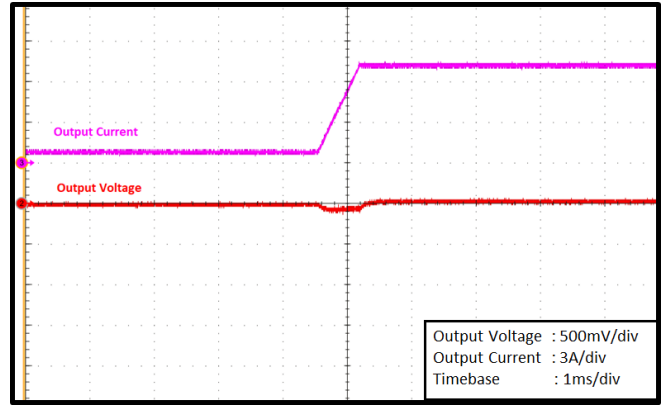


Figure 9. 10-100% Load Transient Response at Nom.  $V_{IN}$

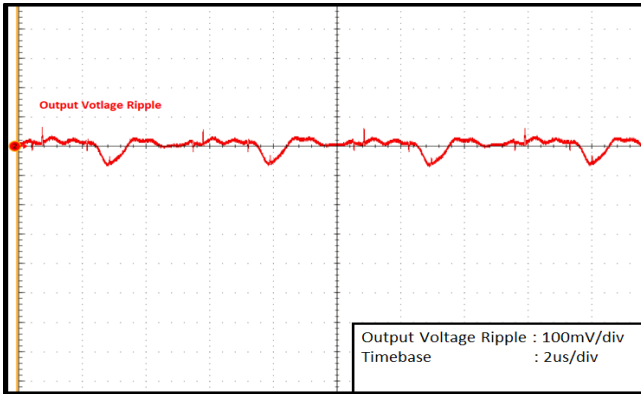


Figure 8.1. Output Ripple  $V_{in} = 19V$  Full Load

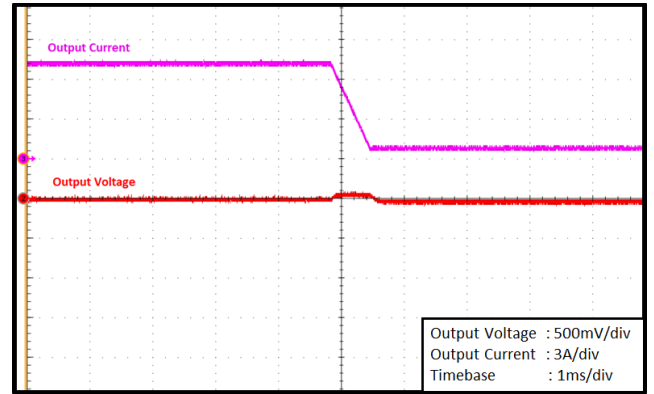


Figure 10. 100-10% Load Transient Response at Nom.  $V_{IN}$

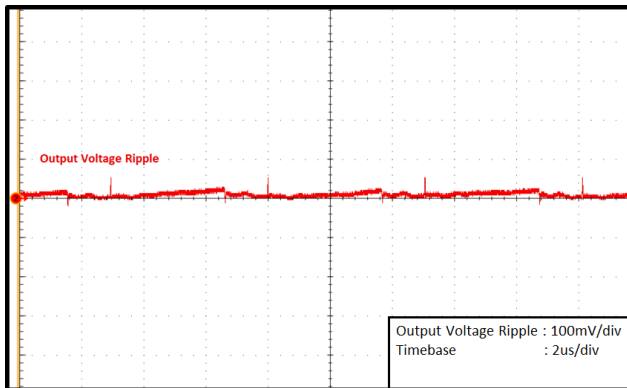


Figure 8.2. Output Ripple  $V_{in} = 28V$  Full Load

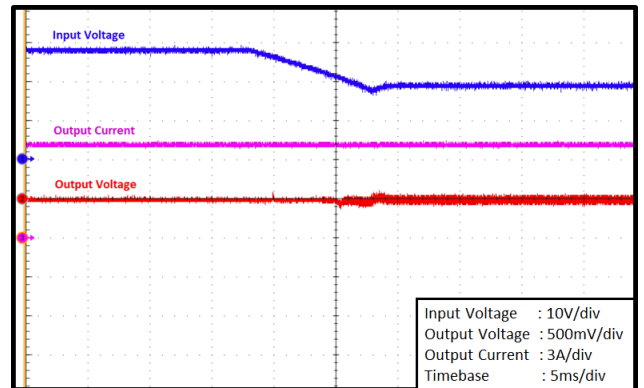
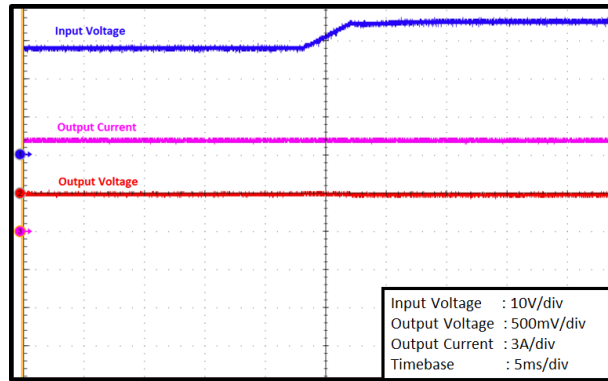
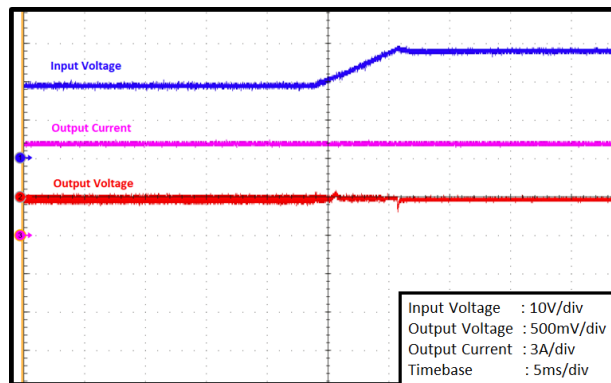


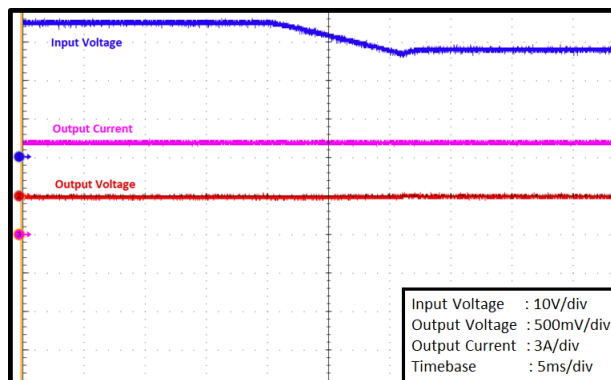
Figure 11.1. 28V-19V Line Transient Response at Full Load ( $\Delta V_{out} \leq 60mV$ )



**Figure 11.2.** 28V-35V Line Transient Response at Full Load ( $\Delta V_{out} \leq 10mV$ )

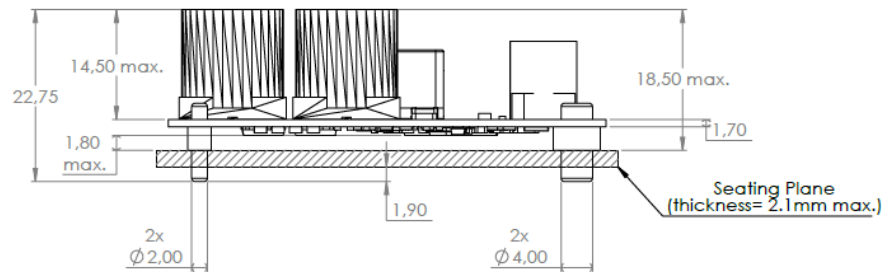
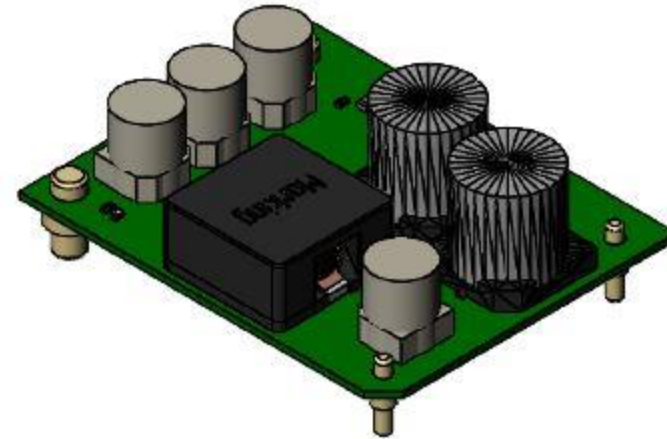
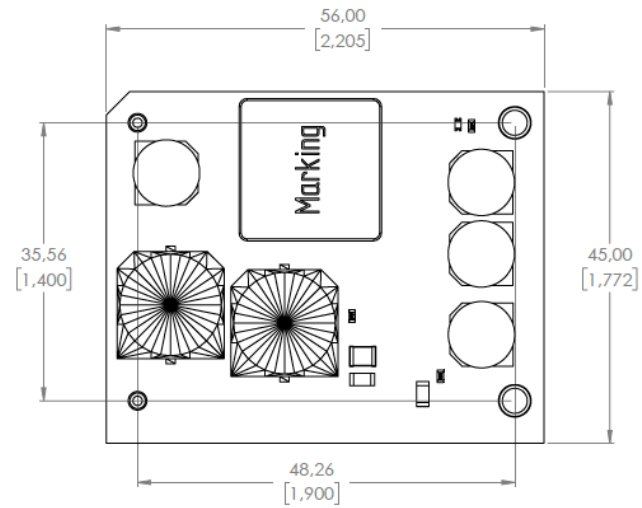


**Figure 12.1.** 19V-28V Line Transient Response at Full Load ( $\Delta V_{out} \leq 160mV$ )



**Figure 12.2.** 35V-28V Line Transient Response at Full Load ( $\Delta V_{out} \leq 10mV$ )

### Mechanical Drawing





### Part Ordering Information

Manufacturer	Manufacturer Part Number	Option Field
KOLT	GDK1007	20

### Revision History

Revision	Date	Description	Page Number(s)
A-PC1	18.06.2020	Initial Release	N/A