

Features & Benefits

- Isolated DC-DC Half Brick
- Up to 500 W Output Power
- 90% Efficiency at Full Load
- Input Under Voltage Lockout
- Input/Output Over Voltage Protection
- Output Current Limit
- Short Circuit Protection
- Thermal Shutdown
- Remote ON/OFF Control
- Output Voltage Remote Sense
- Output Voltage Trim Range +10%, -40%

Compliance

The Converter (with an KRFL filter) is designed to meet:

- MIL-STD-461G
- MIL-STD-810G
- MIL-STD-1275D*
- MIL-HDBK-704-8*

*: details in Standards Compliance table

Typical Applications

- Military/Defense Power Systems
- Armored Vehicles
- Land Platforms
- Aerospace Platforms
- Communications and Radar Systems
- Medical Systems

Product Ratings	
V _{IN}	16 – 40 V
V _{OUT}	12 V
I _{OUT}	42 A
P _{OUT}	500 W

Product Description

KMBM03-DC28-P500-DC12-HB is a 500 W DC/DC converter in half-brick size that operates from nominal 28 V input and generates 12 V isolated output. The converter is fully protected to operate reliably under all kinds of disturbances. The baseplate is designed and manufactured in-house to provide efficient cooling and safe operation at 100 °C base plate temperature.



Size: 61.0 x 58.4 x 13.0 mm
[2.402" x 2.299" x 0.512"]

Weight: 150 ± 5 g

Electrical Characteristics

All data are obtained at nominal line and full load unless otherwise specified. (Ta = 25 °C)

Input Characteristics					
Parameters	Notes & Conditions	Min	Typ	Max	Unit
Non-Operating Input Voltage Range	Continuous	-1		60	V
Input Voltage Transient	1s			42	V
Operating Input Voltage Range		16	28	40	V
Input Under Voltage Turn-On Threshold		15.0	15.5	16	V
Input Under Voltage Turn-Off Threshold		13.8	14.3	14.8	V
Input Over Voltage Turn-On Threshold		40.5	41	41.5	V
Input Over Voltage Turn-Off Threshold		42.7	43.2	43.7	V
No-Load Input Current			660	720	mA
Disabled Input Current			4.2		mA
Input Current Ripple (pk-pk)			110	140	mA
Maximum Input Current	At low line and %10 trim up			38.20	A
Recommended External Input Capacitance	Typ. ESR 0.3-0.4 Ω; See Figure S		500		μF
Recommended External Input Fuse	Fast acting			50	A

Output Characteristics					
Parameters	Notes & Conditions	Min	Typ	Max	Unit
Output Voltage			12		V
Output Voltage Set Point			± 1		%
Output Voltage Line Regulation			± 0.2		%
Output Voltage Load Regulation			± 1		%
Output Voltage Ripple and Noise (pk-pk)	20 MHz bandwidth		120		mV
Operating Output Current Range		0		42	A
Output Current Limit		44			A
Output Current Shutdown Limit			60		A
Output DC Current-Limit Shutdown Voltage			6		V
Output Power			500		W
Maximum Output Capacitance	Nominal output voltage			2.35	mF
Input Voltage Transient Response	50 V/ms; See Figure C				
Step Change	28V to 40V to 28V input voltage		1.5		V
Settling Time	Within 1% output voltage		1.3		ms
Load Current Transient Response	1 A/μs; See Figure B and Figure E				
Step Change	50% to 75% to 50% output load		1		V
Settling Time	Within 1% output voltage		1		ms
Output Voltage Trim Range	Across Sense+ and Sense- Pins	-40		+10	%
Recommended External Output Capacitance	Typ. ESR 0.3-0.4 Ω; See Figure S		100		μF
Output Over-Voltage Protection	At nominal output voltage		14.4		V

General Characteristics					
Parameters	Notes & Conditions	Min	Typ	Max	Unit
Efficiency	From half load to full load	89		90	%
Turn-On Transient Time	Within 90% output voltage		85		ms
Turn-On Transient Output Voltage Overshoot	Maximum output capacitance			1	%
Soft-Start Time	Within 90% output voltage		29		ms
Switching Frequency			150		kHz
Non-Operating ON/OFF Pin Voltage	Continuous	-1		60	V
ON/OFF Control Off-State Voltage		-1		12.2	V
ON/OFF Control On-State Voltage		14.1		40	V
MTBF	Ground Begin, 30°C Ta		3173		10 ³ Hrs.
	Ground Fixed, 40°C Ta		433		10 ³ Hrs.
	Ground Mobile, 45°C Ta		182		10 ³ Hrs.
Over Temperature Shutdown Trip Point	Average PCB Temperature		125		°C
Over Temperature Shutdown Hysteresis			15		°C

Standards Compliance					
MIL-STD-1275D					
Parameters	Min	Typ	Max	Unit	Status
5.1.3.1 Steady-State Voltage	25	-	30	V	Passed
5.1.3.2 Ripple	-	-	2	V	Passed
5.1.3.3 Surges	28	-	40	V	Passed
5.1.4.1 Steady-State Voltage	23	-	33	V	Passed
5.1.4.2 Ripple	-	-	7	V	Passed
MIL-HDBK-704-8					
LDC101	-	-	-	-	Passed
LDC102	16	28	40	V	Passed
LDC105	28	-	100	V	Passed
LDC201	-	-	-	-	Passed
LDC301-704E	20	-	31.5	V	Passed
LDC302-704E	22	-	50	V	Passed
LDC401-704E	18	-	29	V	Passed
LDC501	12	-	29	V	Passed
LDC601	0	-	28	V	Passed

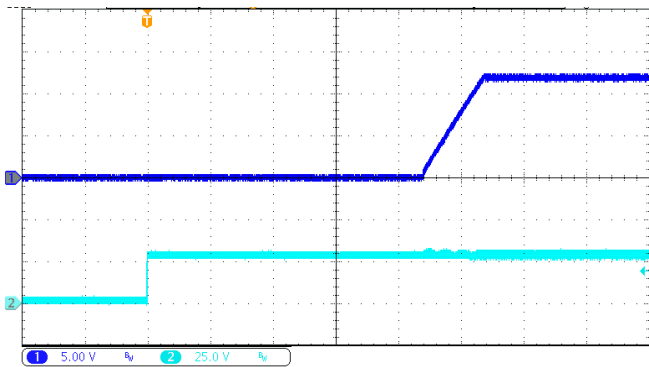

Output voltage (navy blue) (5 V/div) Time base: 20 ms/div
ON/OFF pin voltage (cyan) (25 V/div)

Figure A. Startup waveform under pre-applied input voltage with 1 μ F ceramic and 100 μ F electrolytic capacitor across the load terminals.

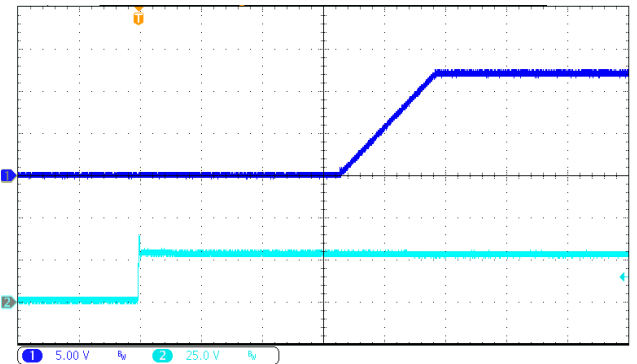

Output voltage (navy blue) (5 V/div) Time base: 20 ms/div
Input voltage (cyan) (25 V/div)

Figure D. Turn on transient at full resistive load with 1 μ F ceramic and 100 μ F electrolytic capacitor across the load terminals.

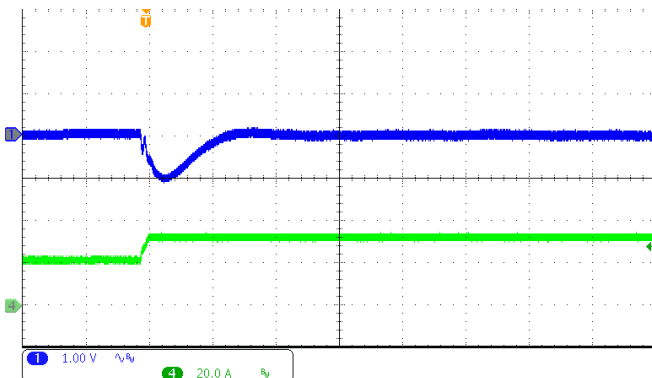

Output voltage (navy blue) (1 V/div) Time base: 400 μ s /div
Output current (green) (20 A/div)

Figure B. Load current transient response (AC Coupled): from 50% to 75% 1 μ F ceramic and 100 μ F electrolytic capacitors across the load terminals ($di/dt = 1 \text{ A}/\mu\text{s}$).

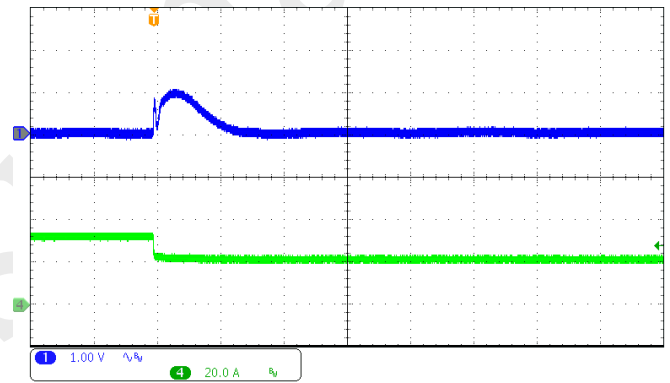

Output voltage (navy blue) (1 V/div) Time base: 400 μ s /div
Output current (green) (20 A/div)

Figure E. Load current transient response (AC Coupled): from 75% to 50% 1 μ F ceramic and 100 μ F electrolytic capacitors across the load terminals ($di/dt = 1 \text{ A}/\mu\text{s}$).

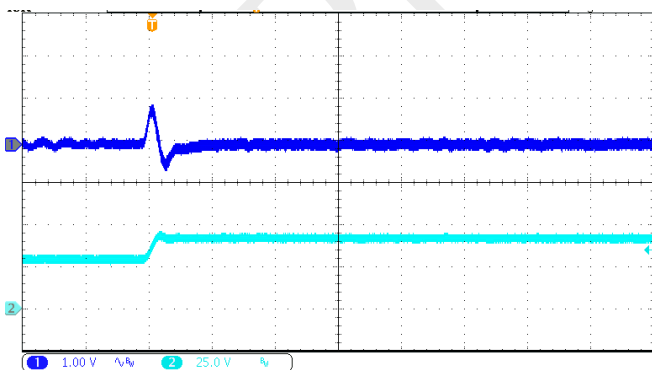

Output voltage (navy blue) (1V/div) Time base: 1 ms/div
Input voltage (cyan) (25 V/div)

Figure C. Input voltage transient response, output voltage (AC Coupled): from 28V to 40V with 1 μ F ceramic and 100 μ F electrolytic capacitor across the load terminals ($dV/dt = 50 \text{ V}/\text{ms}$).

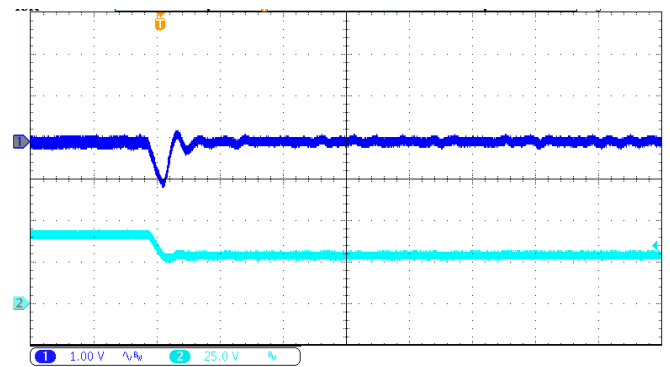

Output voltage (navy blue) (1V/div) Time base: 1 ms/div
Input voltage (cyan) (25 V/div)

Figure F. Input voltage transient response, output voltage (AC Coupled): from 40V to 28V with 1 μ F ceramic and 100 μ F electrolytic capacitor across the load terminals ($dV/dt = 50 \text{ V}/\text{ms}$).

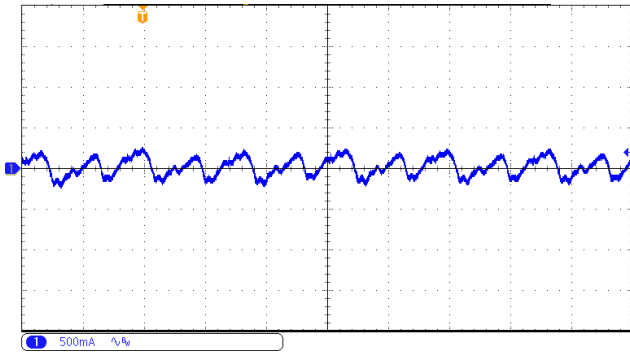

Input current ripple (500 mA/div) Time base: 4 μ s/div

Figure G. Input current ripple at nominal input voltage and full load current with 470 μ F electrolytic capacitor across the input terminals. Bandwidth: 20 MHz

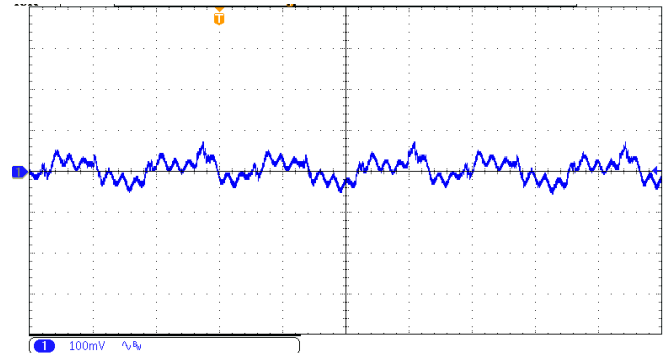

Output voltage ripple (100mV/div) Time base: 2 μ s/div

Figure H. Output voltage ripple at nominal input voltage and full load current with 1 μ F ceramic and 100 μ F electrolytic capacitor across the load terminals.

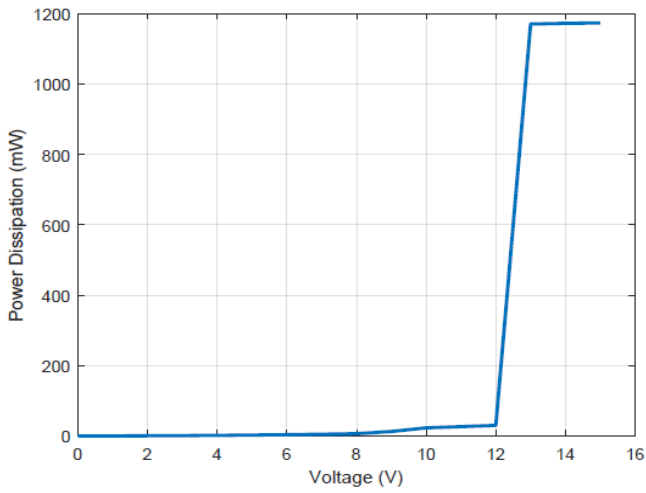

Figure I. Disabled power dissipation versus input voltage

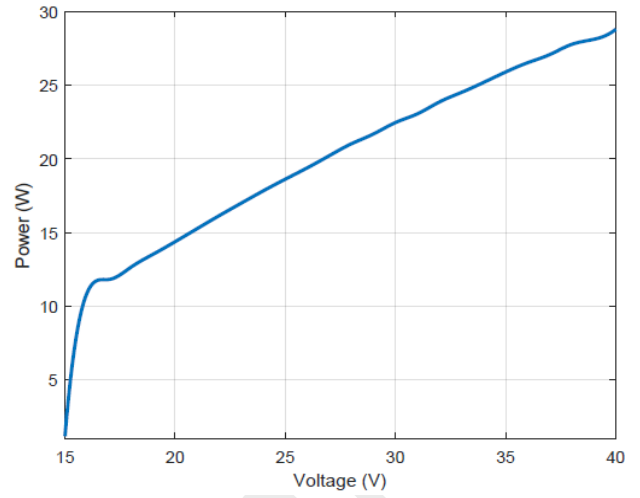

Figure K. Enabled power dissipation versus input voltage

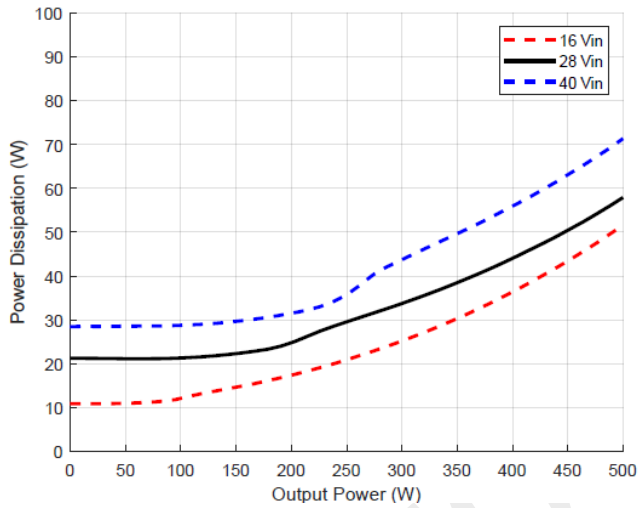

Figure J. Power dissipation versus output power at minimum, nominal and maximum input voltage

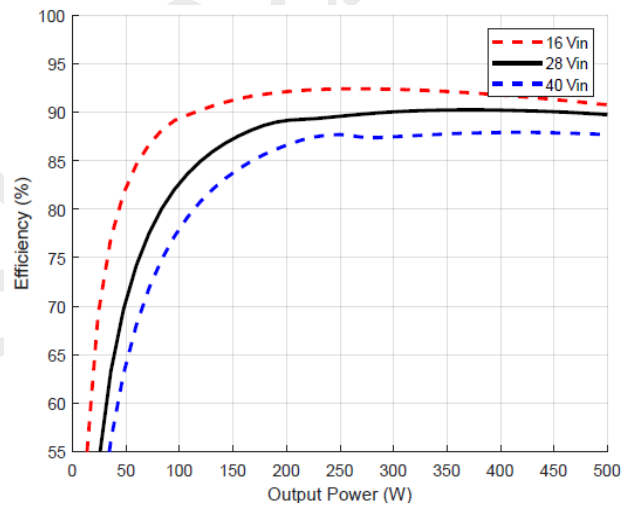

Figure L. Efficiency versus output power at minimum, nominal and maximum input voltage

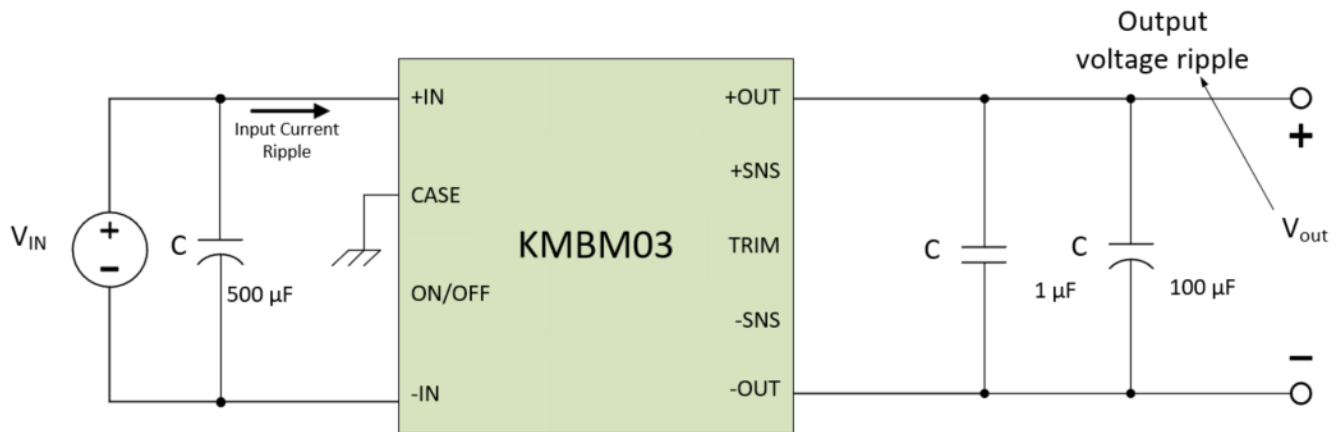

Figure M. Test set-up showing measurement point for output voltage ripple (Figure F).

Basic Operation and Features

REMOTE ON/OFF

The ON/OFF input, Pin 2, allows the user to control the ON and OFF states of the module. This input, which is referenced to the return terminal of the input bus (-IN), is held as active high to keep the module at ON state. If it is pulled down to the return terminal of the input bus (-IN), the converter goes into OFF state. Moreover, the ON/OFF function allows the product to be turned ON/OFF by an external device like a semiconductor or a mechanical switch.

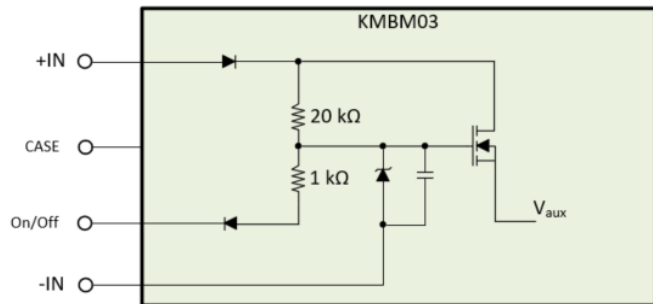

Figure N. Internal ON/OFF circuit

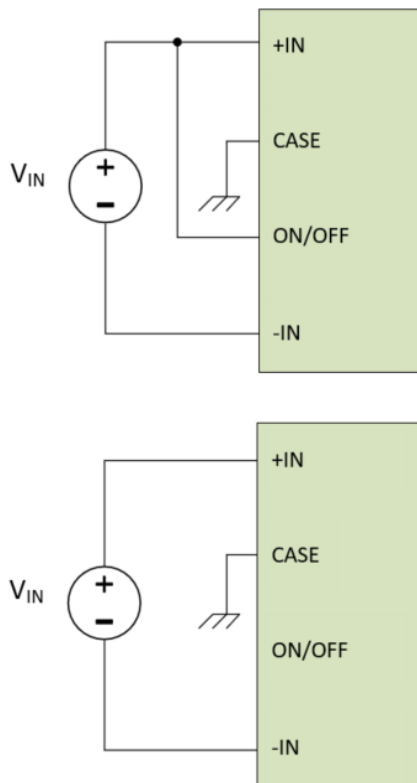

Figure O. Recommended ON state connections

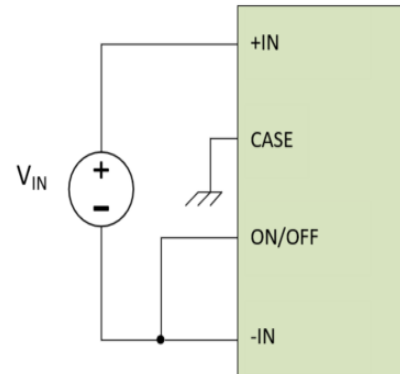

Figure P. Recommended OFF state connection

SENSE

Sense terminals are placed at the load side of the converter module. The sense inputs are used to adjust and fine-tune the output voltage and compensate for any error at the voltage level. If the load is away from the unit, which may require connection over a long pair of cables, connect +SNS and -SNS to the terminal of the load respectively to compensate for the voltage drop across the line.

OUTPUT VOLTAGE TRIM

The TRIM input feature of the module permits the user to adjust the output voltage across the sense leads up or down according to the trim range. The user should connect a resistor between TRIM and +SNS input to decrease the output voltage.

For a desired decrease of the nominal output voltage, the value of the resistor should be calculated as below.

$$R_{TRIM_DOWN} = 2.8 \times \frac{(V_{OUT_{nom}} - 2.06 \times V_{OUT_{desired}})}{(V_{OUT_{desired}} - V_{OUT_{nom}})} \text{ k}\Omega$$

Output Voltage resulting from trim down resistor can be calculated as below. R_{TRIM_DOWN} is trim down resistor's value in kΩ.

$$V_{Generated} = V_{OUT_{nom}} \times \frac{(2.8 + R_{TRIM_DOWN})}{(5.76 + R_{TRIM_DOWN})} V$$

To increase the output voltage, the user should connect a resistor between TRIM and -SNS input.

Converter can regulate output voltage to 28 V at full load, starting from 16 V input voltage.

$$R_{TRIM_UP} = \frac{(2.8 \times V_{OUT_{nom}} - 2 \times V_{OUT_{desired}})}{(V_{OUT_{desired}} - V_{OUT_{nom}})} \text{ k}\Omega$$

Output Voltage resulting from trim up resistor can be calculated as below. R_{TRIM_UP} is trim up resistor's value in kΩ.

$$V_{Generated} = V_{OUT_{nom}} \times \frac{(2.8 + R_{TRIM_UP})}{(2 + R_{TRIM_UP})} V$$

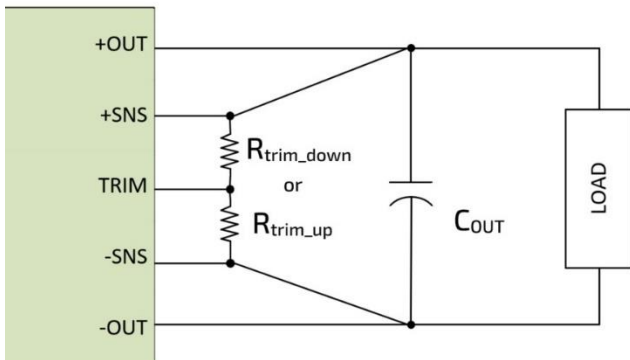

Figure Q. Typical trim application circuit

DROOP CURRENT SHARING

For “droop active” models (part numbers with PR option), output voltage has a 1 V slope from full load to no load. In other words, output voltage of the module is 12.2 V for no load and 11.8 V for full load. This enables safe parallel connection of multiple models.

For connection diagram, please refer to Figure T. ORing diodes (simple diode or ideal diode) are required for parallel connection.

PMBUS

PM option field in KOLT Brick Module part numbers indicate I2C capability. I2C digital interface can be used to monitor input and output parameters.

KMBM03 brick module provides a two-wire I2C compatible communication interface that enables host device to monitor device parameters including Input Voltage, Output Voltage and Current, Device Temperature and Status.

I2C PIN DESCRIPTIONS AND RATINGS

Pin Name	Absolute Maximum Voltage Ratings
PMBUS_C2	3.6 V
GND	3.6 V
PMBUS_SDA*	3.6 V
PMBUS_SMBALERT*	3.6 V
PMBUS_SCL*	3.6 V
PMBUS_ADDRESS*	3.6 V

*: Internal 10kOhm pull-up resistor to 3.3 V

I2C SIGNAL SPECIFICATIONS

Parameter	Min	Typ	Max	Unit
High Level Input Voltage	2.64		3.5	V
Low Level Input Voltage	0		1	V
SDA and SCL Bus Capacitive Load			400	pF
Bus Frequency		100		kHz
Clock Low Time	4.7			µs
Clock High Time	4			µs
SDA and SCL Fall Time			300	ns
SDA and SCL Rise Time			1000	ns
Data Input Setup Time	250			ns
Start Condition Setup Time	4.7			µs
Start Condition Hold Time	4.0			µs
Stop Condition Setup Time	4.0			µs
Stop Condition Hold Time	>0			µs
Bus Free Time	4.7			µs

I2C READ OPERATION

KMBM03 supports 100 kHz bus frequency and always acts as a slave. I2C Master can only read registers of KMBM03. Write to registers is not possible. Read register sequence is detailed in Figure R.



Figure R. Read Register Operation

KMBM03 brick modules incorporate internal 10kOhm pull-up resistors to 3.3V on SDA and SCL lines.

Depending on the bus load SDA and SCL lines may require additional pull-up resistors to 2.8 to 3.5V external supply. Absolute maximum capacitive load on SDA and SCL lines are 400pF.

I2C ID SELECTION

I2C address of device is combination of physical address and Read/Write bit. Default I2C physical address for a KMBM03 brick module is 0x2. Alternate physical I2C address of 0x6 is selected when PMBUS_ADDRESS pin tied to Digital Ground (GND) pin.

PMBUS_ADDRESS Pin State	I2C Address Byte	
	Read	Write
Float	0x3	0x2
Tied to GND	0x7	0x6

I2C REGISTERS

I2C digital interface is used to monitor input, output and status information of converter.

Digital configuration via Write to registers with I2C interface feature for KMBM03 brick modules will be implemented in the future.

Register Address	R/W	Register Name	Scale Factor	Description
0x79	Read Only	STS	-	Status Register
0x88	Read Only	VIN	1mV/LSB	Input Voltage Reading Register
0x8B	Read Only	VOUT	1mV/LSB	Output Voltage Reading Register
0x8C	Read Only	IOUT	1mA/LSB	Output Current Reading Register
0x8D	Read Only	TEMP	1 °C/LSB	Temperature Reading Register

STATUS REGISTER (STS) 0x79

Status Register (0x79) is a 16-bit register containing status information and last logged fault of brick module.

Status Register (STS)							
15	14	13	12	11	10	9	8
Reserved			LOT	LOC	LREG	LOV	LUV
7	6	5	4	3	2	1	0
Reserved			OT	OC	REG	OV	UV

Eight least significant bits (LSBs) of STS (0x79) holds status information of the device. If any bit is set to 1, this indicates output is turned off due to fault conditions described in Status Register Fields table.

Eight most significant bits (MSBs) of STS (0x79) holds last fault log since power up. Fault log can only be cleared by powering down the converter or by pulling Remote ON/OFF pin to OFF state.

Status Register (STS) Fields			
Bits	Field	Reset	Description
0	UV	0	Input Under Voltage Fault bit 1: Input Voltage is lower than "Under Voltage Turn-Off Threshold". 0: Input Voltage is higher than "Under Voltage Turn-On Threshold".
1	OV	0	Input Over Voltage Fault bit 1: Input Voltage is higher than "Over Voltage Turn-Off Threshold". 0: Input Voltage is lower than "Over Voltage Turn-On Threshold".
2	REG	0	Regulation Fault bit 1: Output Voltage is lower than "Output DC Current-Limit Shutdown Voltage" or higher than "Output Over Voltage Protection Limit". 0: Output Voltage is OK.
3	OC	0	Output Over Current Fault bit 1: Output Current is higher than "Output Current Shutdown Limit". 0: Output Current is in operating limits.
4	OT	0	Over Temperature Fault bit 1: Temperature is higher than "Over Temperature Shutdown Trip Point". 0: Temperature is in operating limits.
5-7	Res	0	Reserved
8	LUV	0	Logged Input Under Voltage Fault bit
9	LOV	0	Logged Input Over Voltage Fault bit
10	LREG	0	Logged Regulation Fault bit
11	LOC	0	Logged Output Over Current Fault bit
12	LOT	0	Logged Over Temperature Fault bit
13-15	Res	0	Reserved

INPUT VOLTAGE REGISTER (VIN) 0x88

Input Voltage Register (0x88) is a 16-bit register containing unsigned input voltage reading information of brick module. This register has a scale factor of 1 mV/LSB.

Input Voltage Register (VIN)							
15	14	13	12	11	10	9	8
VIN [15-8]							
7	6	5	4	3	2	1	0
VIN [7-0]							

Lower 8-bit part of VIN (0x88) register holds eight least significant bits (LSBs) of input voltage reading.

Upper 8-bit part of VIN (0x88) register holds eight most significant bits (MSBs) of input voltage reading.

Input Voltage Register (VIN) Fields			
Bits	Field	Reset	Description
0-15	VIN	0	Input Voltage Reading 0 = 0 V 1 = 0.001 V . . 28000 = 28.0 V . . 50000 = 50.0 V

OUTPUT VOLTAGE REGISTER (VOUT) 0x8B

Output Voltage Register (0x8B) is a 16-bit register containing unsigned output voltage reading information of brick module. This register has a scale factor of 1 mV/LSB.

Output Voltage Register (VOUT)							
15	14	13	12	11	10	9	8
VOUT [15-8]							
7	6	5	4	3	2	1	0
VOUT [7-0]							

Lower 8-bit part of VOUT (0x8B) register holds eight least significant bits (LSBs) of output voltage reading.

Upper 8-bit part of VOUT (0x8B) register holds eight most significant bits (MSBs) of output voltage reading.

Output Voltage Register (VOUT) Fields			
Bits	Field	Reset	Description
0-15	VOUT	0	Output Voltage Reading 0 = 0 V 1 = 0.001 V . . 28000 = 28.0 V . . 50000 = 50.0 V

OUTPUT CURRENT REGISTER (IOUT) 0x8C

Output Current Register (0x8C) is a 16-bit register containing unsigned output current reading information of brick module. This register has a scale factor of 1 mV/LSB.

Output Current Register (IOUT)							
15	14	13	12	11	10	9	8
IOUT [15-8]							
7	6	5	4	3	2	1	0
IOUT [7-0]							

Lower 8-bit part of IOUT (0x8C) register holds eight least significant bits (LSBs) of output current reading.

Upper 8-bit part of IOUT (0x8C) register holds eight most significant bits (MSBs) of output current reading.

Output Current Register (IOUT) Fields			
Bits	Field	Reset	Description
0-15	IOUT	0	Output Current Reading 0 = 0 A 1 = 0.001 A . . 10700 = 10.7 A . . 50000 = 50.0 A

TEMPERATURE REGISTER (TEMP) 0x8D

Temperature Register (0x8D) is a 16-bit register containing temperature reading information of brick module in twos complement format. This register has a scale factor of 1 °C/LSB

Temperature Register (TEMP)							
15	14	13	12	11	10	9	8
TEMP [15-8]							
7	6	5	4	3	2	1	0
TEMP [7-0]							

Lower 8-bit part of TEMP (0x8D) register holds eight least significant bits (LSBs) of temperature reading.

Upper 8-bit part of TEMP (0x8D) register holds eight most significant bits (MSBs) of temperature reading.

Temperature Register (TEMP) Fields			
Bits	Field	Reset	Description
0-15	TEMP	0	Temperature Reading 155: 155 °C . . 1: 1 °C 0: 0 °C 65535: -1 °C . 65481: -55 °C

Protection Features

Input Under Voltage Lockout

The converter module starts operating when the input voltage is raised above the "Under Voltage Turn-On Threshold". Once turned on, turn off is initiated when the input falls below the "Under Voltage Turn-Off Threshold". The "Module Input Specifications" Table gives the associated table.

Input Over Voltage Protection

The converter module protects itself by ceasing operation when input goes above the "Over Voltage Turn-Off Threshold". It resumes operation when input falls below the "Over Voltage Turn-On Threshold". The "Module Input Specifications" Table gives the associated limits.

Output Current Limit

The converter will derate the output voltage if the output current exceeds the "Output Current Limit" value. If the over load condition is resolved, the control output voltage will increase to the nominal value.

Output Over Voltage Protection

If the output voltage exceeds the "Output Over Voltage-Protection" value the converter outputs are disabled immediately and retries after cooldown period. The "Output Over Voltage Protection Limit" is 120% of Output Voltage. If trim up or down is used protection limit will change according to output voltage setting.

Output Over Current Protection

If the output current exceeds the "Output Current Shutdown Limit" value the converter outputs are disabled immediately and retries after cooldown period.

Short Circuit Protection

The short circuit condition is an extreme case of the Output Current Limit condition. When output Voltage drops below "Output DC Current-Limit Shutdown Voltage" limit, the converter outputs are disabled immediately and retries after cooldown period. The "Output DC Current-Limit Shutdown Voltage" is 50% of Output Voltage. If trim up or down is used protection limit will change according to output voltage setting.

Over Temperature Shutdown

The brick has a thermistor located at the hottest point inside the module. The thermal shutdown circuit is designed to turn the converter off when the temperature at the sensed location goes above the "Over Temperature Shutdown" limit. It locks itself and waits to cool off. The Converter then resumes operation automatically when the temperature of the sensed location falls below the trip point by the amount equal to the "Over Temperature Shutdown Hysteresis"

Application Considerations

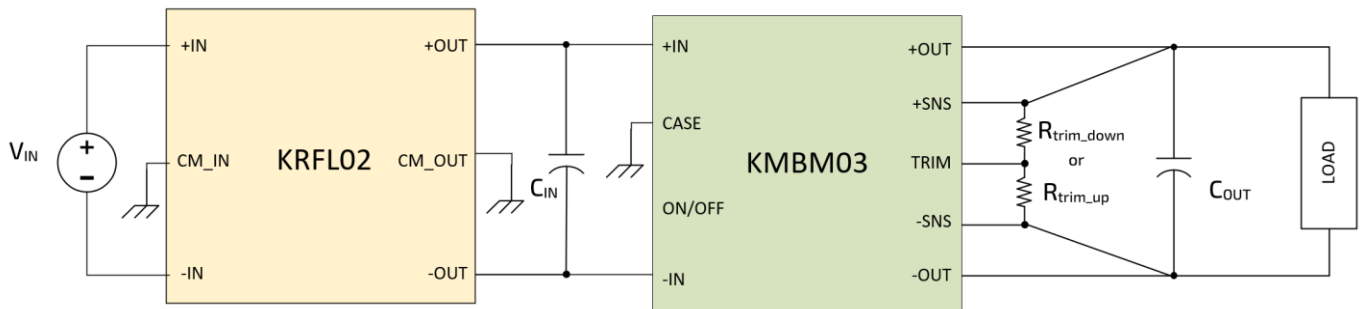

Figure S. Typical application

NOTE: If the output voltage is to be used in its default state, there is no need to use trim resistors.

C_{IN}: 5 parallel 160SGV100M18x16.5 (100uF 160V Aluminum-Electrolytic Capacitor)

C_{OUT}: EEE-FTH101XAP (100uF 50V Aluminum-Electrolytic Capacitor)

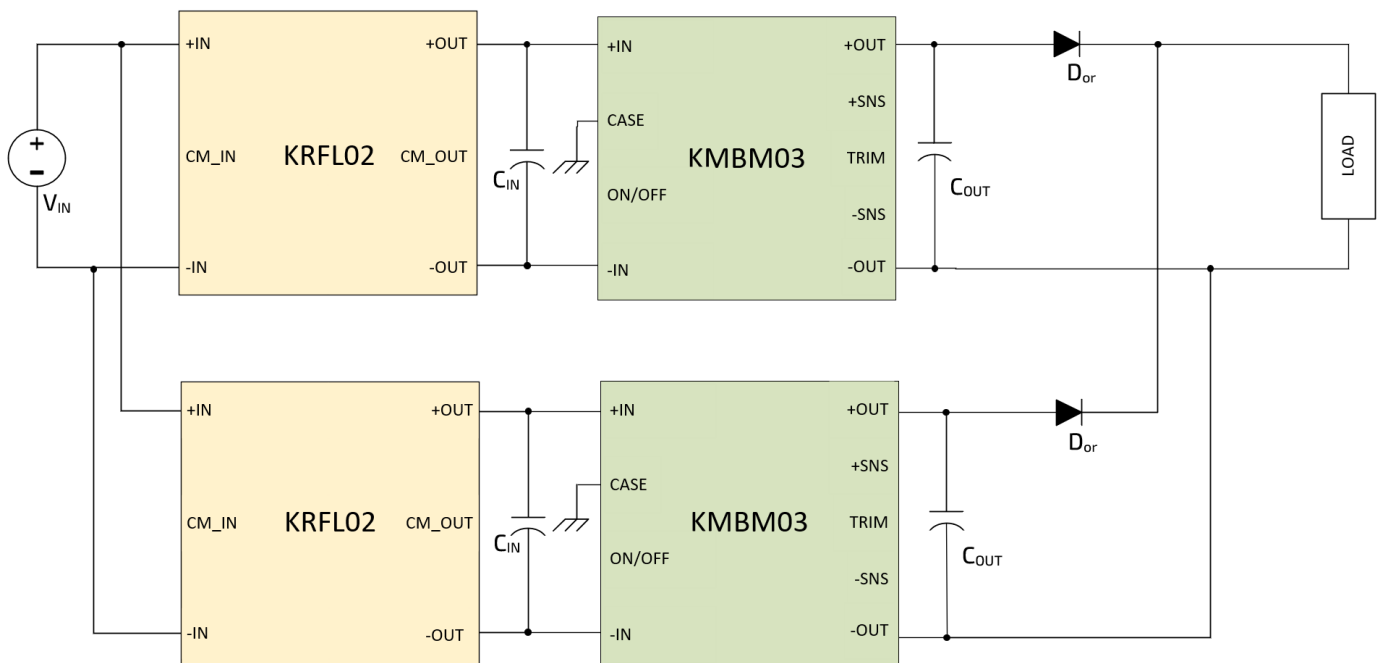

Figure T. Recommended application N+1 redundant parallel connection

C_{IN}: 5 parallel 160SGV100M18x16.5 (100uF 160V Aluminum-Electrolytic Capacitor)

C_{OUT}: EEE-FTH101XAP (100uF 50V Aluminum-Electrolytic Capacitor)

D_{or}: Can be either an ORing diode or ideal diode driver circuit

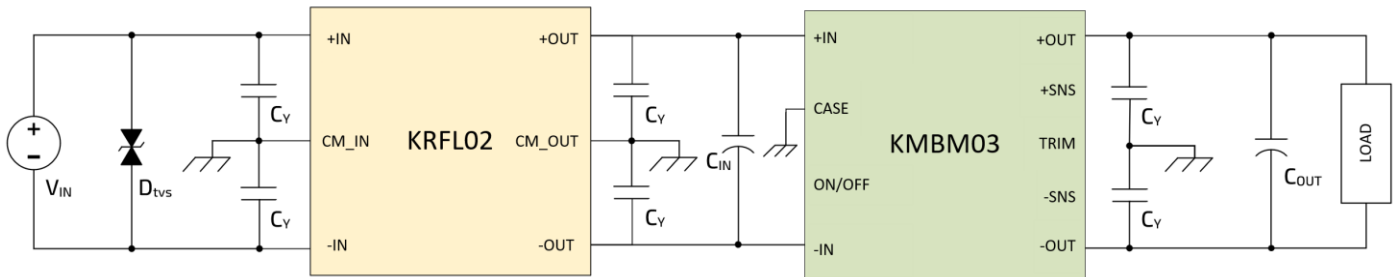

Figure U. Recommended Application for better EMI/EMC compliance

CM_IN and CM_OUT of KRFL02 should be connected to the chassis.

C_Y: CHV1206N2K0472KXT (4700 pF 2kV X7R Ceramic Capacitor)

C_{IN}: : 5 parallel 160SGV100M18x16.5 (100uF 160V Aluminum-Electrolytic Capacitor)

C_{OUT}: EEE-FTH101XAP (100uF 50V Aluminum-Electrolytic Capacitor)

D_{tvS}: 5.0SMDJ40CA (Bi-directional 40Vwm TVS Diode)

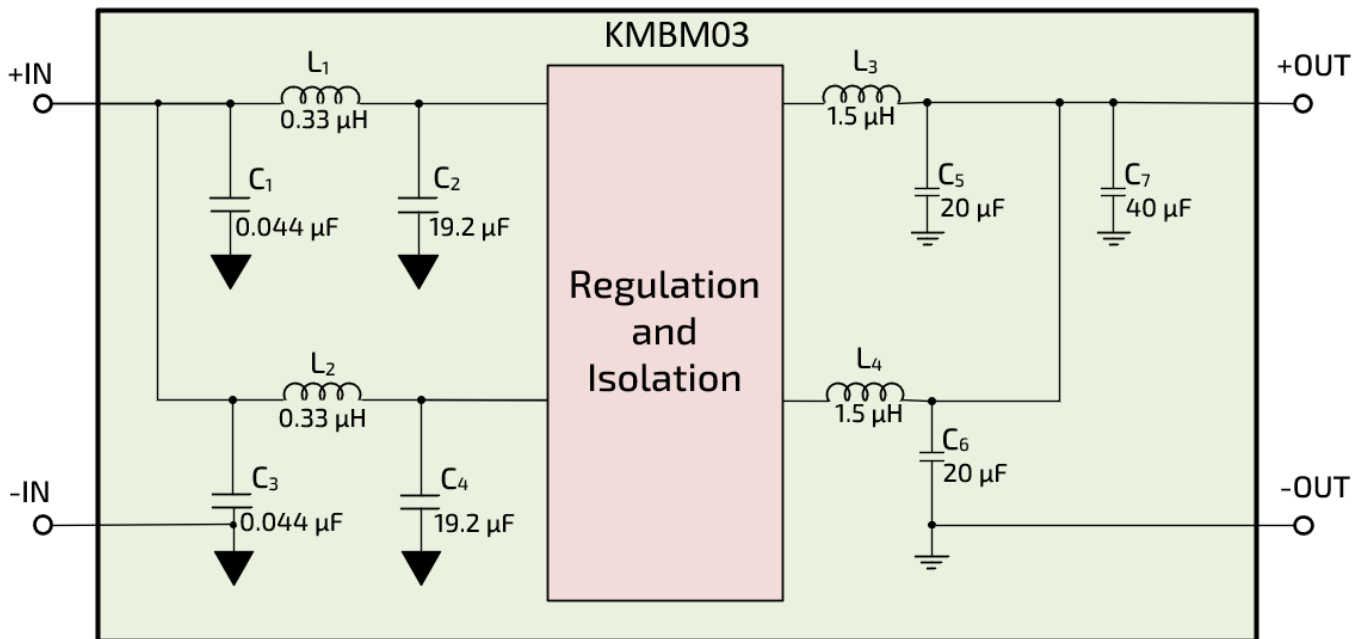
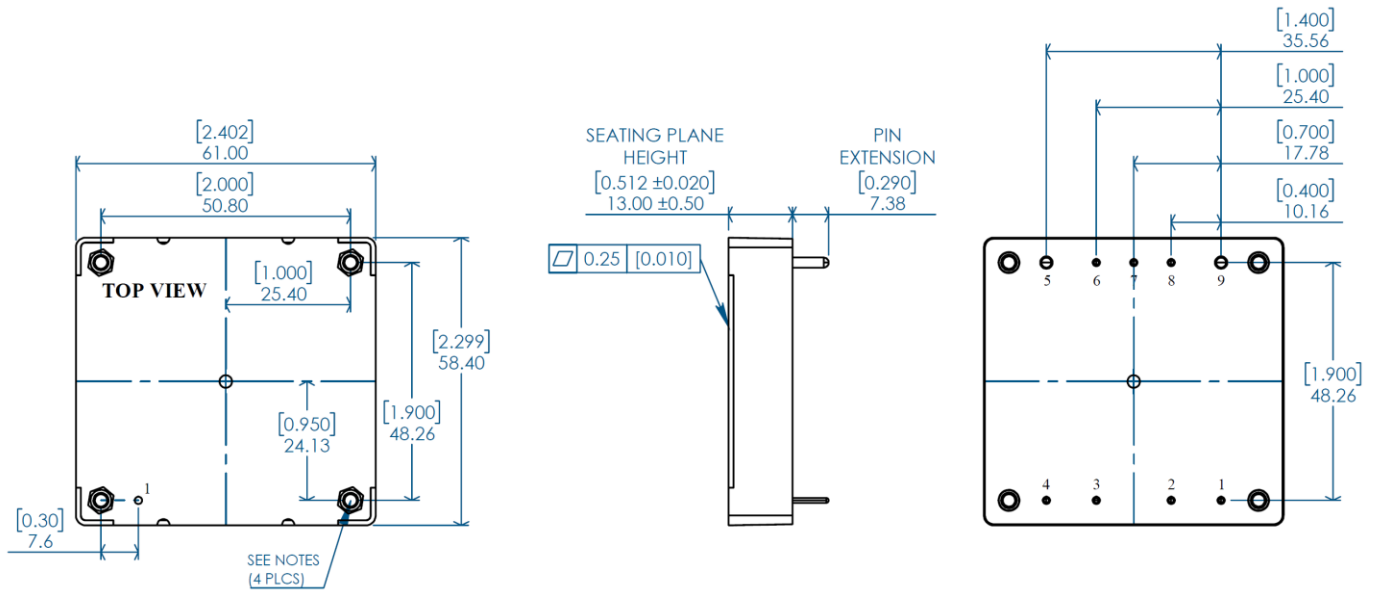

Figure V. Internal input and output filter diagram of KMBM03

Mechanical Drawing – Threaded



NOTES:

- APPLIED TORQUE PER M3 SCREW 0.45Nm (4in-lb) RECOMMENDED [0.56Nm (5in-lb) LIMIT]. M3 SCREW SHOULD NOT EXCEED 6mm (0.236") DEPTH BELOW THE SURFACE OF THE BASEPLATE.
- BASEPLATE FLATNESS TOLERANCE IS 0.25mm (0.010") TIR FOR SURFACE.
- PINS 1-4 AND 6-8 ARE 1.02mm DIA. (0.040") WITH 1.83mm DIA. (0.072") STANDOFFS.
- PINS 5 AND 9 ARE 2.03mm DIA. (0.080") WITH 3.18mm DIA. (0.125") STANDOFFS.
- PINS 1-9
MATERIAL: BRASS ALLOY
FINISH: 10µ" GOLD OVER NICKEL
- WEIGHT: 151.4 g (5.34 oz)
- ALL DIMENSIONS IN MILLIMETERS [inches]
- TOLERANCES: X.Xmm ±0.5mm (X.XXIN ±0.020)
X.XXmm ±0.25mm (X.XXXIN ±0.010)

Pin	Name	Function
1	+IN	Positive input voltage
2	ON/OFF	Remote on/off, referenced to -IN
3	CASE	Chassis connection
4	-IN	Input return
5	-OUT	Output return
6	-SNS	Negative remote sense
7	TRIM	Output voltage trim
8	+SNS	Positive remote sense
9	+OUT	Positive output voltage

Mechanical Drawing – Flanged

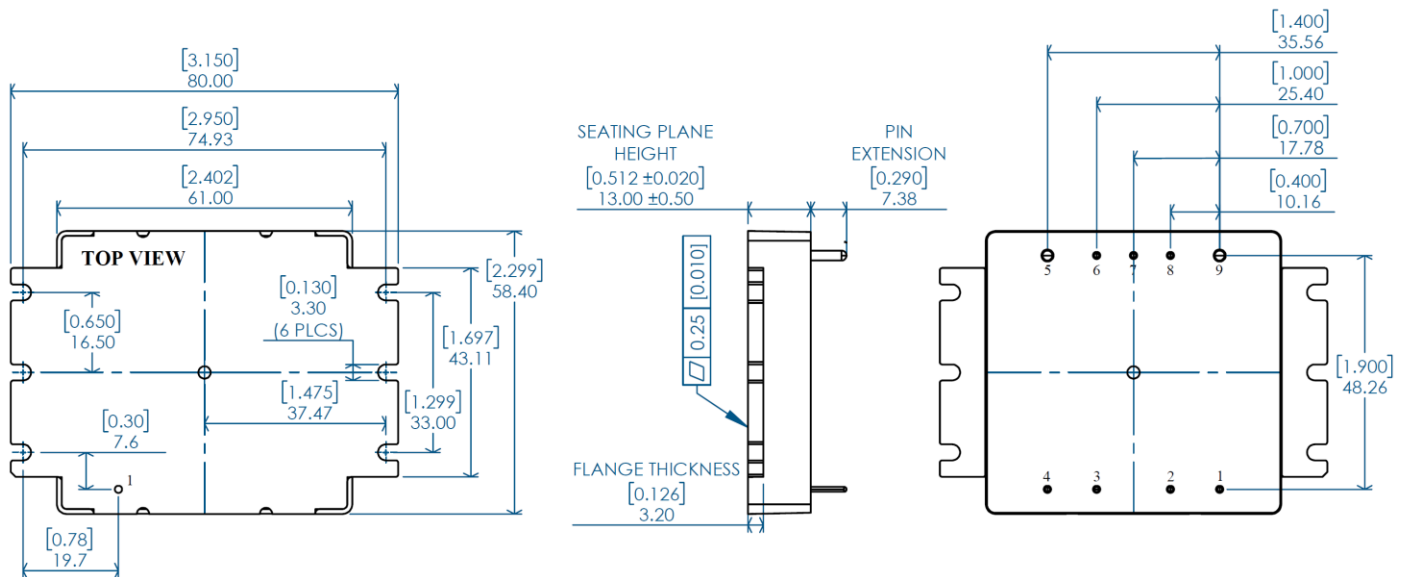

NOTES:

- APPLIED TORQUE PER M3 SCREW 0.45Nm (4in-lb) RECOMMENDED [0.56Nm (5in-lb) LIMIT].
- BASEPLATE FLATNESS TOLERANCE IS 0.25mm (0.010") TIR FOR SURFACE.
- PINS 1-4 AND 6-8 ARE 1.02mm DIA. (0.040") WITH 1.83mm DIA. (0.072") STANDOFFS.
- PINS 5 AND 9 ARE 2.03mm DIA. (0.080") WITH 3.18mm DIA. (0.125") STANDOFFS.
- PINS 1-9
MATERIAL: BRASS ALLOY
FINISH: 10µ" GOLD OVER NICKEL
WEIGHT: 157.9 g (5.57 oz)
- ALL DIMENSIONS IN MILLIMETERS [inches]
- TOLERANCES: X.Xmm ±0.5mm (X.XXIN ±0.020)
X.XXmm ±0.25mm (X.XXXIN ±0.010)

Pin	Name	Function
1	+IN	Positive input voltage
2	ON/OFF	Remote on/off, referenced to -IN
3	CASE	Chassis connection
4	-IN	Input return
5	-OUT	Output return
6	-SNS	Negative remote sense
7	TRIM	Output voltage trim
8	+SNS	Positive remote sense
9	+OUT	Positive output voltage

Mechanical Drawing – Threaded & PMBUS Capable

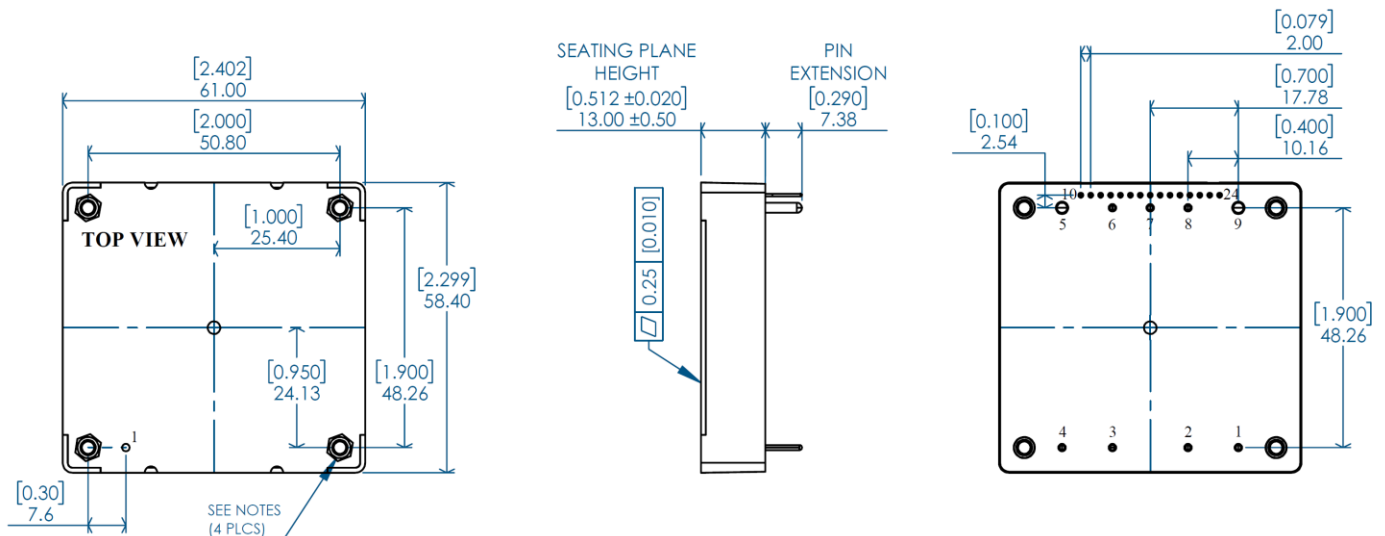

NOTES:

- APPLIED TORQUE PER M3 SCREW 0.45Nm (4in-lb)
RECOMMENDED [0.56Nm (5in-lb) LIMIT]. M3 SCREW SHOULD NOT EXCEED 6mm (0.236") DEPTH BELOW THE SURFACE OF THE BASEPLATE.
- BASEPLATE FLATNESS TOLERANCE IS 0.25mm (0.010") TIR FOR SURFACE.
- PINS 1-4 AND 6-8 ARE 1.02mm DIA. (0.040") WITH 1.83mm DIA. (0.072") STANDOFFS.
- PINS 5 AND 9 ARE 2.03mm DIA. (0.080") WITH 3.18mm DIA. (0.125") STANDOFFS.
- PM OPTION PINS 10-24 ARE 0.50mm x 0.50mm SQUARE
- PINS 1-9
MATERIAL: BRASS ALLOY
FINISH: 10µ" GOLD OVER NICKEL
- PM OPTION PINS 10-24
MATERIAL: PHOSPHOR BRONZE
FINISH: 10µ" GOLD OVER NICKEL
- WEIGHT: 152.25 g (5.37 oz)
- ALL DIMENSIONS IN MILLIMETERS [inches]
- TOLERANCES: X.Xmm ±0.5mm (X.XXIN ±0.020)
X.XXmm ±0.25mm (X.XXXIN ±0.010)

Pin	Name	Function
1	+IN	Positive input voltage
2	ON/OFF	Remote on/off, referenced to -IN
3	CASE	Chassis connection
4	-IN	Input return
5	-OUT	Output return
6	-SNS	Negative remote sense
7	TRIM	Output voltage trim
8	+SNS	Positive remote sense
9	+OUT	Positive output voltage
10	SYNCH	Active Current Synchronization
11*	DATA-	RS485 Data-
12*	DATA+	RS485 Data+
13*	PMBUS_C2	I2C Control
14*	GND	Digital Ground
15*	PMBUS_SDA	I2C Data
16*	PMBUS_SMBALERT	I2C slave to master alert
17*	PMBUS_SCL	I2C Clock
18*	PMBUS_ADDRESS	I2C address selection
19*	NC	No-connect
20*	NC	No-connect
21*	NC	No-connect
22*	NC	No-connect
23*	NC	No-connect
24*	NC	No-connect

*: AVAILABLE ON PMBUS OPTION

Mechanical Drawing – Flanged & PMBUS Capable

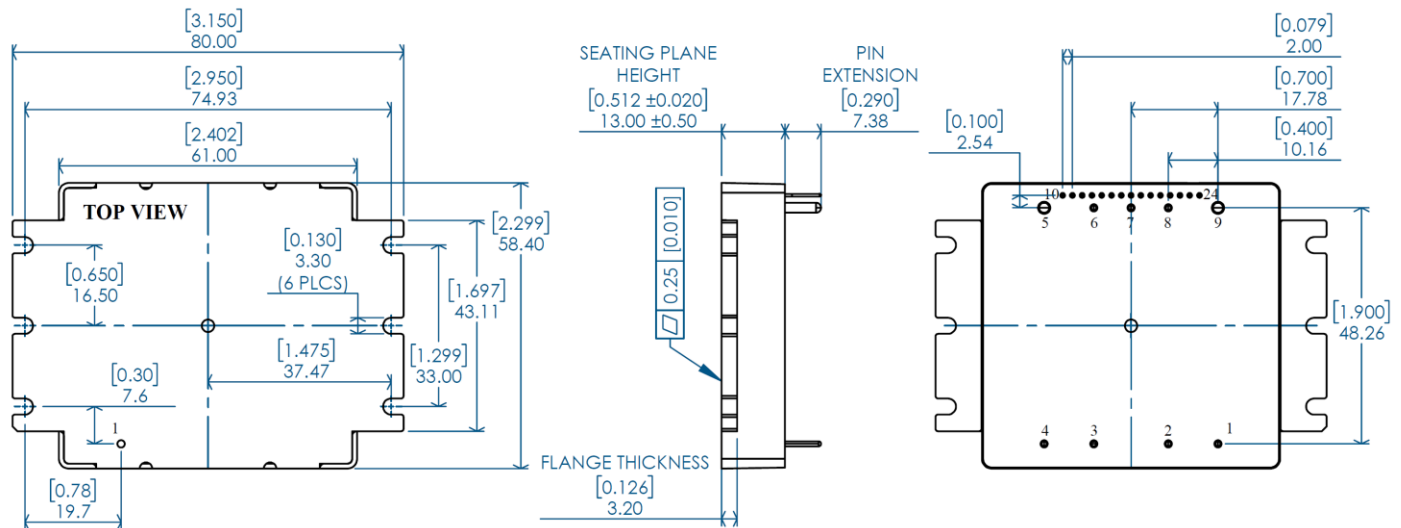

NOTES:

- APPLIED TORQUE PER M3 SCREW 0.45Nm (4in-lb) RECOMMENDED [0.56Nm (5in-lb) LIMIT].
- BASEPLATE FLATNESS TOLERANCE IS 0.25mm (0.010") TIR FOR SURFACE.
- PINS 1-4 AND 6-8 ARE 1.02mm DIA. (0.040") WITH 1.83mm DIA. (0.072") STANDOFFS.
- PINS 5 AND 9 ARE 2.03mm DIA. (0.080") WITH 3.18mm DIA. (0.125") STANDOFFS.
- PM OPTION PINS 10-24 ARE 0.50mm x 0.50mm SQUARE
- PINS 1-9
MATERIAL: BRASS ALLOY
FINISH: 10μ" GOLD OVER NICKEL
- PM OPTION PINS 10-24
MATERIAL: PHOSPHOR BRONZE
FINISH: 10μ" GOLD OVER NICKEL
- WEIGHT: 158.75 g (5.6 oz)
- ALL DIMENSIONS IN MILLIMETERS [inches]
- TOLERANCES: X.Xmm ±0.5mm (X.XXIN ±0.020)
X.XXmm ±0.25mm (X.XXXIN ±0.010)

Pin	Name	Function
1	+IN	Positive input voltage
2	ON/OFF	Remote on/off, referenced to -IN
3	CASE	Chassis connection
4	-IN	Input return
5	-OUT	Output return
6	-SNS	Negative remote sense
7	TRIM	Output voltage trim
8	+SNS	Positive remote sense
9	+OUT	Positive output voltage
10	SYNCH	Active Current Synchronization
11*	DATA-	RS485 Data-
12*	DATA+	RS485 Data+
13*	PMBUS_C2	I2C Control
14*	GND	Digital Ground
15*	PMBUS_SDA	I2C Data
16*	PMBUS_SMBALERT	I2C slave to master alert
17*	PMBUS_SCL	I2C Clock
18*	PMBUS_ADDRESS	I2C address selection
19*	NC	No-connect
20*	NC	No-connect
21*	NC	No-connect
22*	NC	No-connect
23*	NC	No-connect
24*	NC	No-connect

*: AVAILABLE ON PMBUS OPTION

Part Ordering Information

Family	Input Voltage	Power	Output Voltage	Package	Option Field
KMBM03	DC28 28 VDC	P500 500 W	DC12 12 VDC	HB Half Brick	F: Flanged PM: PMBUS PR: Droop Active

Ordering Number	Baseplate	Communication	Droop
KMBM03-DC28-P500-DC12-HB	Threaded	No communication capability, PMBUS pins are absent.	Passive
KMBM03-DC28-P500-DC12-HB-F	Flanged	No communication capability, PMBUS pins are absent.	Passive
KMBM03-DC28-P500-DC12-HB-PR	Threaded	No communication capability, PMBUS pins are absent.	Active
KMBM03-DC28-P500-DC12-HB-F-PR	Flanged	No communication capability, PMBUS pins are absent.	Active
KMBM03-DC28-P500-DC12-HB-PM	Threaded	With PMBUS communication capability	Passive
KMBM03-DC28-P500-DC12-HB-F-PM	Flanged	With PMBUS communication capability	Passive
KMBM03-DC28-P500-DC12-HB-PM-PR	Threaded	With PMBUS communication capability	Active
KMBM03-DC28-P500-DC12-HB-F-PM-PR	Flanged	With PMBUS communication capability	Active

Revision History

Document Number	Revision	Date	Description	Page Number(s)
107141	01	19.10.2024	Initial Release	-

Contact

www.koltpower.com**KOLT Türkiye**salesturkiye@koltpower.com

KOLT Mühendislik A.Ş.

Serhat Mah. 1148. Sok. No:1B/1
06374 Yenimahalle, Ankara
Türkiye**KOLT Europe**saleseurope@koltpower.com

KOLT Power Ltd.

Fareham Innovation Centre Merlin
House. 4 Meteor way. Daedalus Drive.
Fareham. Lee-On-Solent PO13 9FU.
United Kingdom**KOLT North America**salesna@koltpower.com

KOEN, Inc.

2445 Augustine Dr. Suite 150
Santa Clara, CA 95054
United States

Connect with us

[kolt-inc](https://www.linkedin.com/company/kolt-inc)[kolt.inc](https://www.facebook.com/kolt.inc)[KOLTEngineering](https://twitter.com/KOLTEngineering)[kolthq](https://www.instagram.com/kolthq)

The information provided in this datasheet is believed to be accurate and reliable. However, KOLT assumes no responsibility for any consequences arising from its use, nor for any infringement of patents or other rights of third parties that may result from its use. These products are sold only under KOLT's general terms and conditions of sale, unless otherwise specified in writing. Specifications are subject to change without notice. All rights reserved.