

Features & Benefits

- Operating Input Voltage Range 16 - 40 V
- Up to 300 W Output Power
- 92% Efficiency at Full Load Current
- Input Under Voltage Lockout
- Input/Output Over Voltage Protection
- Output Current Limit
- Short Circuit Protection
- Thermal Shutdown
- Remote ON/OFF Control
- Output Voltage Remote Sense
- Output Voltage Trim Range +10%*, -40%

*: Trim-up capability input voltage range 18-40V_{DC}

Compliance

Converter (with an KRFL filter) is designed to meet:

- MIL-STD-461G
- MIL-STD-810G
- MIL-STD-1275E

Typical Applications

- Military/Defense Power Systems
- Armored Vehicles
- Land Platforms
- Aerospace Platforms
- Communications and Radar Systems
- Medical Systems

Product Ratings	
V _{IN}	16–40 V _{DC}
V _{IN_NOM}	28 V _{DC}
V _{OUT}	28 V _{DC}
I _{OUT_MAX}	10.7 A _{DC}
P _{OUT_MAX}	300 W

Product Description

KMBM02-DC28-P300-DC28-QB is a 300 W DC/DC converter in quarter-brick size that operates from nominal 28 V input and generates 28 V isolated output. It is designed to meet MIL-STD-461 EMI requirements when combined with the passive KRFL01 EMI filter module and has superior noise and ripple performance. Converter is fully protected to operate reliably under all kinds of disturbances. Baseplate is designed and manufactured in house to provide efficient cooling and safe operation at 100 °C base plate temperature.

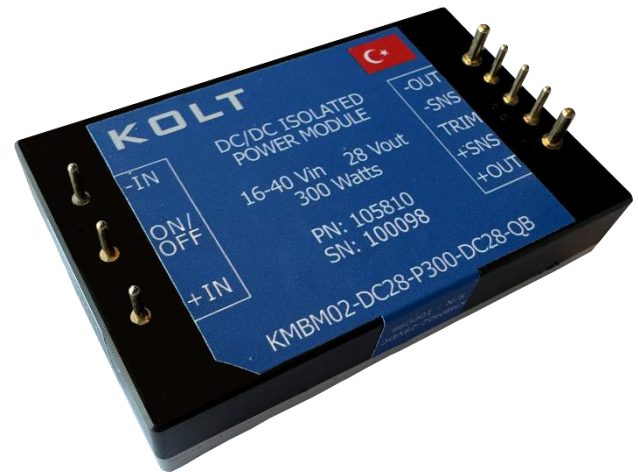

Size: 58.4 x 36.8 x 12.9 mm
[2.3" x 1.45" x 0.51"]

Weight: 80.1 g

Recommended alternative KMBM08-DC28-P300-DC28-QB

Electrical Characteristics

All data are obtained at nominal line and full load unless otherwise specified. (Ta = 25 °C)

Input Characteristics					
Parameters	Notes & Conditions	Min	Typ	Max	Unit
Non-Operating Input Voltage Range	Continuous	-1		60	V
Input Voltage Transient	1s			42	V
Operating Input Voltage Range		16	28	40	V
Under Voltage Turn-On Threshold		15.5	16	16.5	V
Under Voltage Turn-Off Threshold		14.5	15	15.5	V
Over Voltage Turn-On Threshold		36	36.5	37	V
Over Voltage Turn-Off Threshold		40	40.5	41	V
No-Load Input Current			217	251	mA
Disabled Input Current			1.5		mA
Recommended External Input Capacitance	Typ. ESR 0.1-0.2 Ω; See Figure L		440		μF
Recommended External Input Fuse	Fast acting			30	A

Output Characteristics					
Parameters	Notes & Conditions	Min	Typ	Max	Unit
Output Voltage			28		V
Output Voltage Set Point				± 1	%
Output Voltage Line Regulation				± 0.2	%
Output Voltage Load Regulation				± 0.2	%
Output Voltage Ripple and Noise	20 MHz bandwidth		350	400	mV _{PK-PK}
Operating Output Current Range		0		10.7	A
Output Current Limit				11	A
Output DC Current-Limit Shutdown Voltage			14		V
Output Power			300		W
Maximum Output Capacitance	Nominal output voltage			3	mF
Input Voltage Transient Response	50 V/ms; See Figure C				
Step Change	28V to 40V to 28V input voltage		1.2	1.5	V
Settling Time	Within 1% output voltage		5		ms
Load Current Transient Response	1 A/μs; See Figure E and Figure B				
Step Change	50% to 75% to 50% output load		0.8	1	V
Settling Time	Within 1% output voltage		50		μs
Output Voltage Trim Range	Across Sense+ and Sense- Pins	-40		+10	%
Recommended External Output Capacitance	Typ. ESR 0.3-0.4 Ω; See Figure L		100		μF
Output Over-Voltage Protection				33.6	V

General Characteristics					
Parameters	Notes & Conditions	Min	Typ	Max	Unit
Efficiency	From half load to full load	91			%
Turn-On Transient Time	Within 90% output voltage		35		ms
Turn-On Transient Output Voltage Overshoot	Maximum output capacitance		1		%
Soft-Start Time	Within 90% output voltage		5		ms
Switching Frequency			150		kHz
Non-Operating ON/OFF Pin Voltage	Continuous	-1		60	V
ON/OFF Control Off-State Voltage		-1		10	V
ON/OFF Control On-State Voltage		16		40	V
MTBF	Ground Fixed, 40°C Ta		586		10 ³ Hrs.
Over Temperature Shutdown Trip Point			115		°C
Over Temperature Shutdown Hysteresis			15		°C

Isolation Characteristics					
Parameters	Notes & Conditions	Min	Typ	Max	Unit
Insulation Resistance	500V _{DC}				
Input to Base Plate			>45		GΩ
Output to Base Plate			>45		GΩ
Isolation Voltage	60s dwell, 1mA trip current				
Input to Output			2250		V _{DC}
Input to Base Plate			2250		V _{DC}
Output to Base Plate			2250		V _{DC}

Environmental Characteristics						
Parameters	Standard	Min	Typ	Max	Unit	Status
Operational Baseplate Temperature	MIL-STD-810G_CHG-1 Method 501.6/502.6 Procedure II	-40	-	+100	°C	Passed*
Storage / Transport Temperature	MIL-STD-810G_CHG-1 Method 501.6/502.6 Procedure I	-55	-	+125	°C	Passed*
Operational Low Pressure	MIL-STD-810G_CHG-1 Method 500.6 Procedure II	-	-	3000	m	Passed*
Storage / Transport Low Pressure	MIL-STD-810G_CHG-1 Method 500.6 Procedure I	-	-	9000	m	Designed to Meet
Parameters	Standard	Waveform	Peak Value	Pulse Duration	Axis	Status
Shock	MIL-STD-810G_CHG-1 Method 516.7 Procedure I	Half-Sine	10g	11 ms	±X, ±Y, ±Z	Passed*
Parameters	Standard	Category	Figure	Platform	Vehicle	Status
Vibration	MIL-STD-810G_CHG-1 Method 514.7 Procedure I	Category 4	514.7C-2	Secured Cargo	Truck Transportation and Composite Wheeled Vehicles	Passed*
		Category 8	514.7C-8	Aircraft	Propeller	Passed*
		Category 11	514.7C-11	Railroad	Train	Passed*
		Category 20	514.7C-4	Ground	Wheeled Vehicles	Passed*
		Category 21	514.7D-9	Watercraft	Marine Vehicles	Passed*
Parameters	Standard	Condition				Status
Salt Fog	MIL-STD-810G_CHG-1 Method 509.6	24 hours spray, 24 hours dry, applied 2 times				Designed to Meet
Sand and Dust	MIL-STD-810G_CHG-1 Method 510.6 Procedure I/II	<150 µm Dust 150-850 µm Sand				Designed to Meet
Fungus	MIL-STD-810G_CHG-1 Method 508.7	Analysis of the degree of inertness to fungus growth of the components.				Analysis
Solar Radiation	MIL-STD-810G_CHG-1 Method 505.6 Procedure I	A2				Passed*
Humidity	MIL-STD-810G_CHG-1 Method 507.6 Procedure II	≥ %95 Relative @30°C				Passed*
Parameters	Standard	Test				Status
EMI/EMC	MIL-STD-461G Ground Army	CE102	CS101 CS114 CS115 CS116 CS118	RE102	RS103	Passed*

* Verified in a multi-channel power supply with an KRFL01 filter.

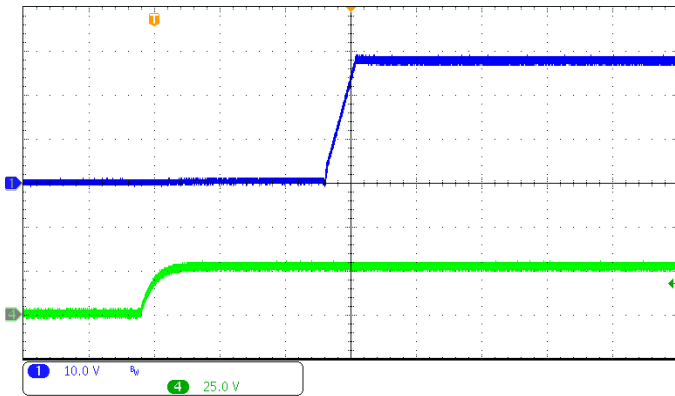

Output voltage (blue) (10 V/div) Time base: 10 ms/div
ON/OFF pin voltage (green) (25 V/div)

Figure A. Startup waveform, input voltage pre-applied with 1 μF ceramic and 100 μF electrolytic capacitor across the load terminals

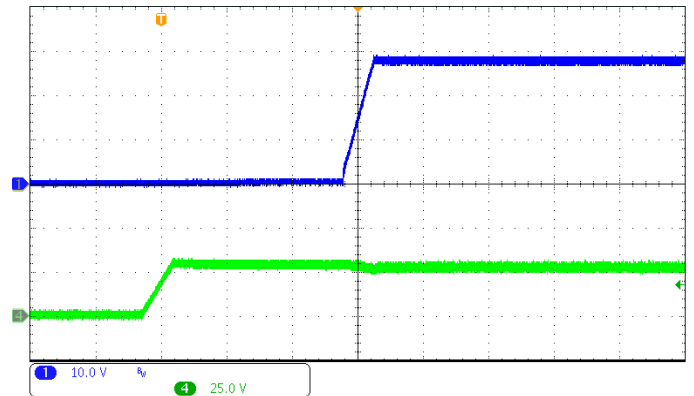

Output voltage (blue) (10 V/div) Time base: 10 ms/div
Input voltage (green) (20 V/div)

Figure D. Turn on transient at full resistive load with 1 μF ceramic and 100 μF electrolytic capacitor across the load terminals

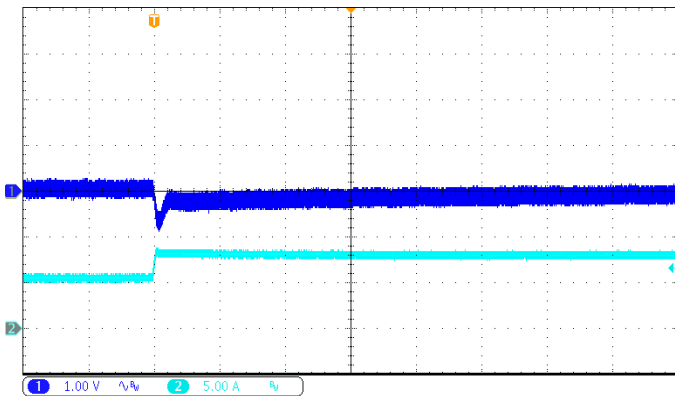

Output voltage (blue) (1 V/div) Time base: 200 μs /div
Output current (light blue) (5 A/div)

Figure B. Load current transient response (AC Coupled): from 50% to 75% with 1 μF ceramic and 100 μF electrolytic capacitor across the load terminals ($di/dt = 1 \text{ A}/\mu\text{s}$)

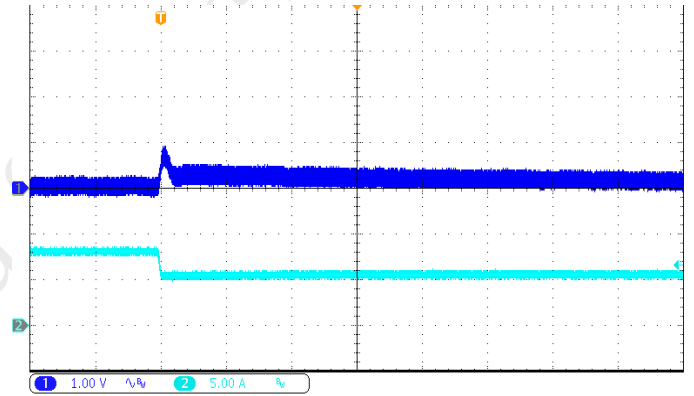

Output voltage (blue) (1 V/div) Time base: 200 μs /div
Output current (light blue) (5 A/div)

Figure E. Load current transient response (AC Coupled): from 75% to 50% with 1 μF ceramic and 100 μF electrolytic capacitor across the load terminals. ($di/dt = 1 \text{ A}/\mu\text{s}$)

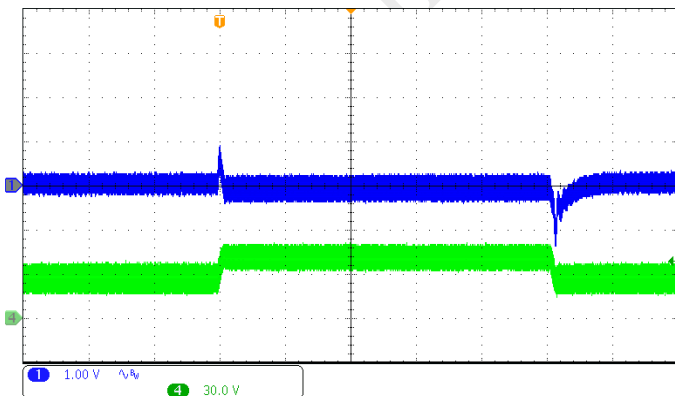

Output voltage (blue) (1 V/div) Time base: 10 ms/div
Input voltage (green) (30 V/div)

Figure C. Input voltage transient response (AC Coupled): from 28 V to 40 V and 40 V to 28 V with 1 μF ceramic and 100 μF electrolytic capacitors across the load terminals. ($dV/dt = 50 \text{ V}/\text{ms}$)

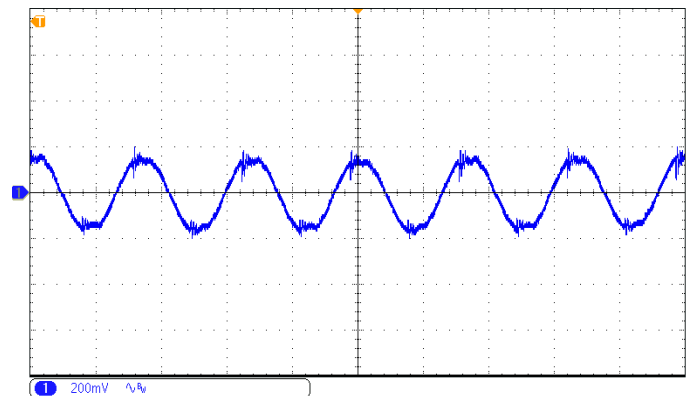

Output voltage ripple (200 mV/div) Time base: 2 μs /div

Figure F. Output voltage ripple at nominal input voltage and full load current with 1 μF ceramic and 100 μF electrolytic capacitor across the load terminals. Bandwidth: 20 MHz

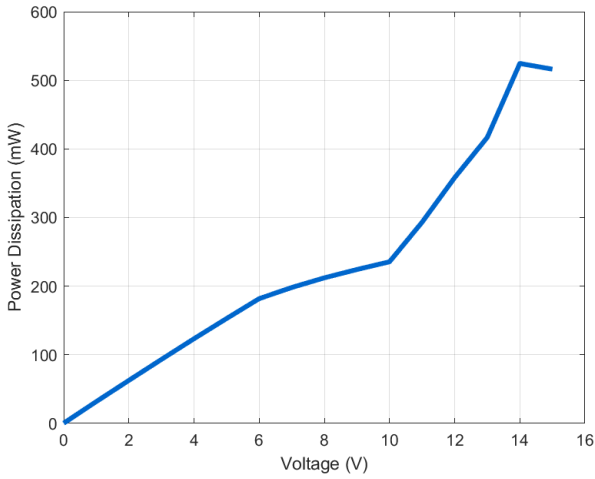

Figure G. Disabled power dissipation versus input voltage

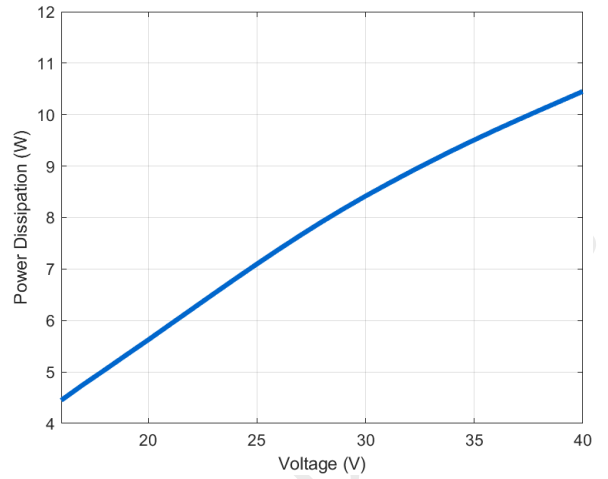

Figure J. Enabled power dissipation versus input voltage

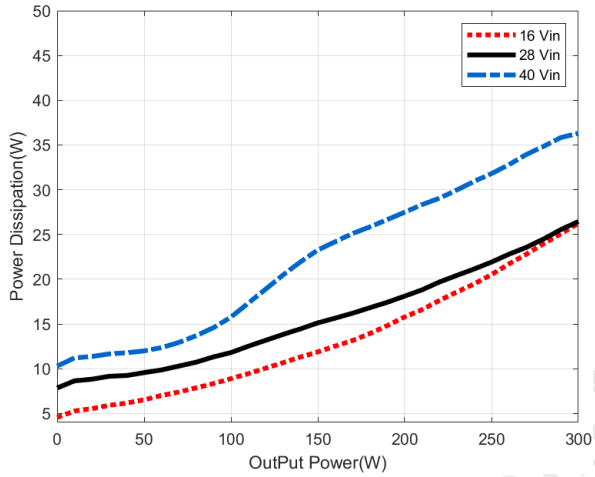

Figure H. Power dissipation versus output power at minimum, nominal and maximum input voltage

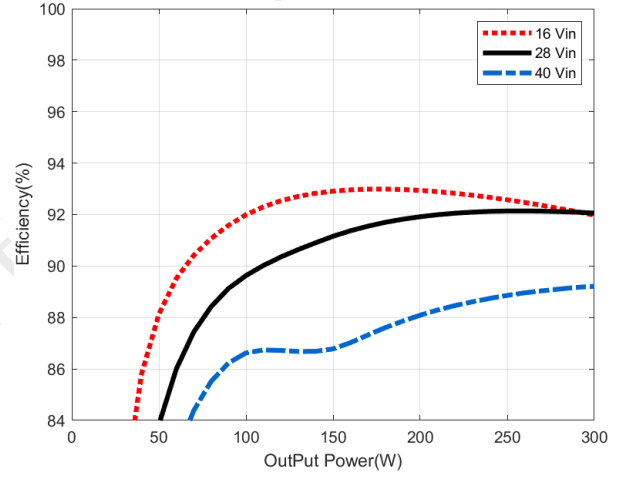

Figure K. Efficiency versus output power at minimum, nominal and maximum input voltage

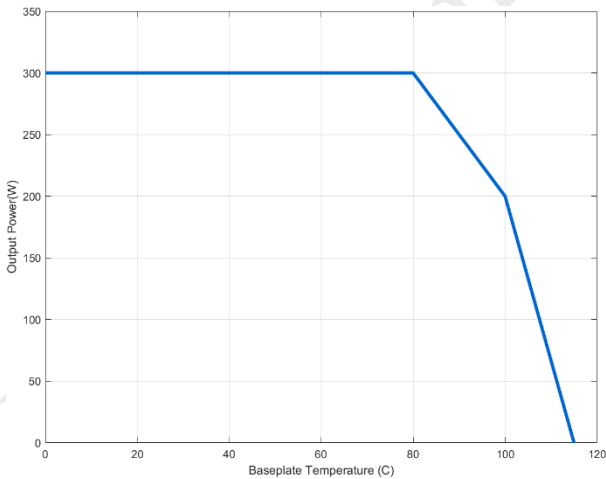

Figure I. Thermal Derating (maximum output power vs baseplate temperature) at nominal input voltage

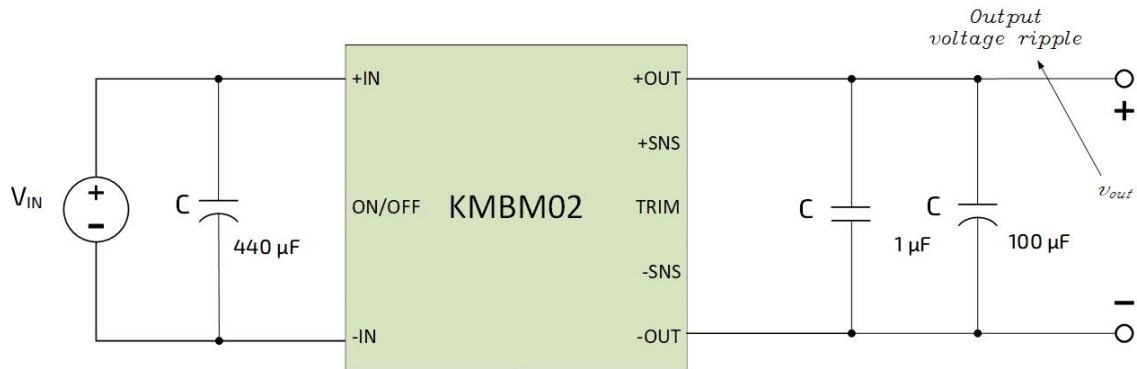

Figure L. Test set-up showing measurement point for output voltage ripple (Figure F).

Not Recommended for New Designs

Basic Operation and Features

REMOTE ON/OFF

The ON/OFF input, Pin 2, allows the user to control the ON and OFF states of the module. This input, which is referenced to the return terminal of the input bus (-IN), is hold as active high to keep the module at ON state. If it is pulled down to the return terminal of the input bus (-IN), converter goes into OFF state. Moreover, the ON/OFF function allows the product to be turned on/off by an external device like a semiconductor or a mechanical switch.

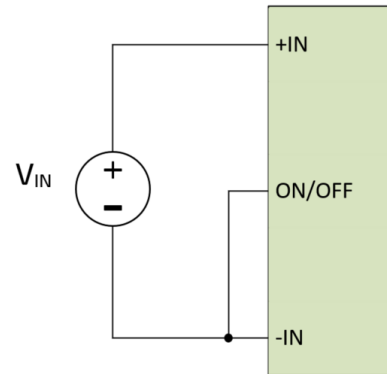

Figure O. Recommended OFF State Connection

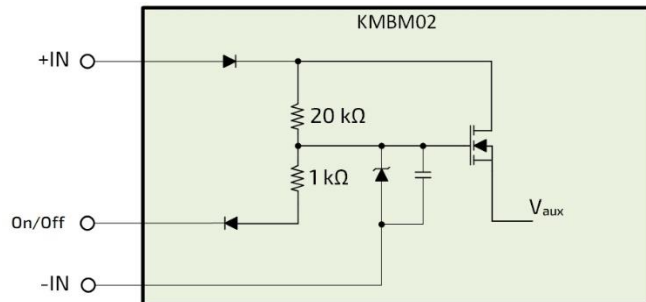

Figure M. Internal ON/OFF Circuit

SENSE

Sense terminals are placed at the load side of the converter module. The sense inputs are used to adjust and fine tune the output voltage and compensate for any error at the voltage level. If the load is away from the unit, which may require connection over a long pair of cable, connect +SNS and -SNS to the terminal of the load respectively to compensate for the voltage drop across the line.

OUTPUT VOLTAGE TRIM

TRIM input feature of the module permits the user to adjust the output voltage across the sense leads up or down according to the trim range. To decrease the output voltage, the user should connect a resistor between TRIM and +SNS input.

For a desired decrease of the nominal output voltage, the value of the resistor should be calculated as below.

$$R_{TRIM_DOWN} = 9.18 * \frac{(V_{OUT_{nom}} - V_{OUT_{desired}} * 1.99)}{(V_{OUT_{desired}} - V_{OUT_{nom}})} k\Omega$$

Output Voltage resulting from trim down resistor can be calculated as below. R_{TRIM_DOWN} is trim down resistor's value in $k\Omega$.

$$V_{Generated} = V_{OUT_{nom}} * \frac{(9.18 + R_{TRIM_DOWN})}{(R_{TRIM_DOWN} + 18.27)} V$$

To increase the output voltage, the user should connect a resistor between TRIM and -SNS input. For input voltages below 18 V at full-load, converter is not able to regulate output voltage above 28 V. So, for lower than 18 V input voltages, trim-up capability is limited.

Converter is able to regulate output voltage to 28 V at full load, starting from 16 V input voltage.

For a desired increase of the nominal output voltage, the value of the resistor should be calculated as below.

$$R_{TRIM_UP} = \frac{(9.18 * V_{OUT_{nom}} - V_{OUT_{desired}} * 8.25)}{(V_{OUT_{desired}} - V_{OUT_{nom}})} k\Omega$$

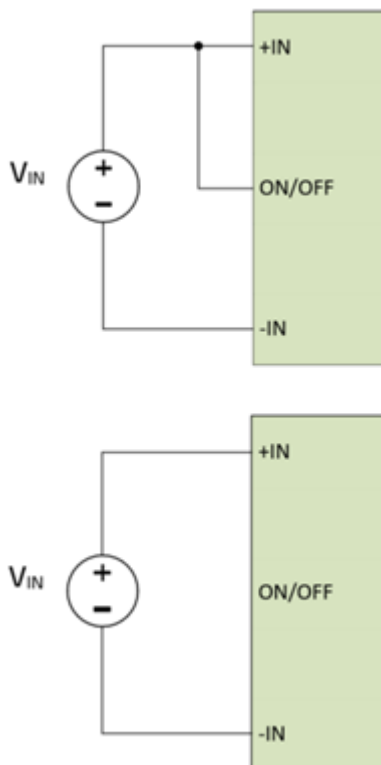

Figure N. Recommended ON State Connections

Output Voltage resulting from trim up resistor can be calculated as below. R_{TRIM_UP} is trim up resistor's value in $k\Omega$.

$$V_{Generated} = V_{OUT_{nom}} * \frac{(9.18 + R_{TRIM_UP})}{(R_{TRIM_UP} + 8.25)} V$$

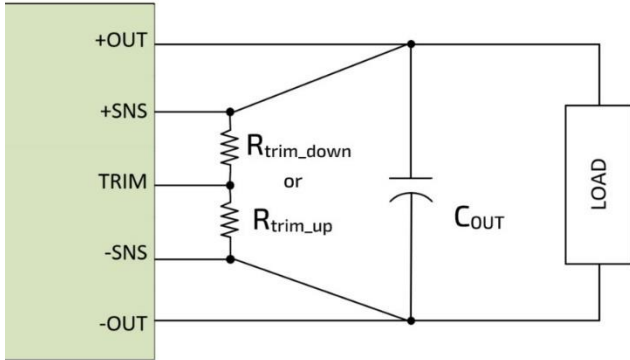

Figure P. Typical Trim Application Circuit

DROOP CURRENT SHARING

For “droop active” models (part numbers with PR option), output voltage has a 1 V slope from full load to no load. In other words, output voltage of the module is 28.5 V for no load and 27.5 V for full load. This enables safe parallel connection of multiple models.

For connection diagram, please refer to Figure R. Recommended Application N+1 Redundant Parallel Connection Figure R. ORing diodes (simple diode or ideal diode) are required for parallel connection.

PMBUS

This module offers a PMBUS digital interface that enables the user to monitor input voltage, output voltage, output current, and device temperature. The PMBUS interface uses the two-wire I2C standard during communication.

Please refer to 105847 KMBM02 I2C Communication Manual for detailed information on PMBUS capability.

Protection Features

Input Under Voltage Lockout

Converter module starts operating when input voltage is raised above "Under Voltage Turn-On Threshold". Once turned-on, turn off is initiated when input falls below "Under Voltage Turn-Off Threshold". The associated limits are given in "Module Input Specifications" Table.

Input Over Voltage Protection

Converter module protects itself by ceasing operation when input goes above "Over Voltage Turn-Off Threshold". It resumes operation when input falls below "Over Voltage Turn-On Threshold". The associated limits are given in "Module Input Specifications" Table.

Output Current Limit

If the output current exceeds the "Output Current Limit" value, the converter will immediately stop operating. The control waits for 500 ms and resets the fault status automatically and resumes operation with soft start. If the fault condition is still persisting, its shuts off again. This sequence is repeated indefinitely.

Output Over Voltage Protection

The default output OVP limit is set to 20% above the nominal output voltage. When detected, protection control responds immediately by shutting down the converter and disabling the outputs. Start sequence is similar to the output current limit case.

Short Circuit Protection

The short circuit condition is an extreme case of the Output Current Limit condition. When the fast rise of the current during a short circuit condition is detected by the dedicated controller, the outputs of the converter are disabled immediately. The sequence of operation after a short circuit detection is similar to hiccup concept described in "Output Current Limit" section.

Over Temperature Shutdown

The brick has a thermistor located at the hottest point inside the module. The thermal shutdown circuit is designed to turn the converter off when the temperature at the sensed location goes above the "Over Temperature Shutdown" limit. It locks itself and waits to cool off. Converter then resumes operation automatically when the temperature of the sensed location falls below the trip point by the amount equal to the "Over Temperature Shutdown Hysteresis"

Application Considerations

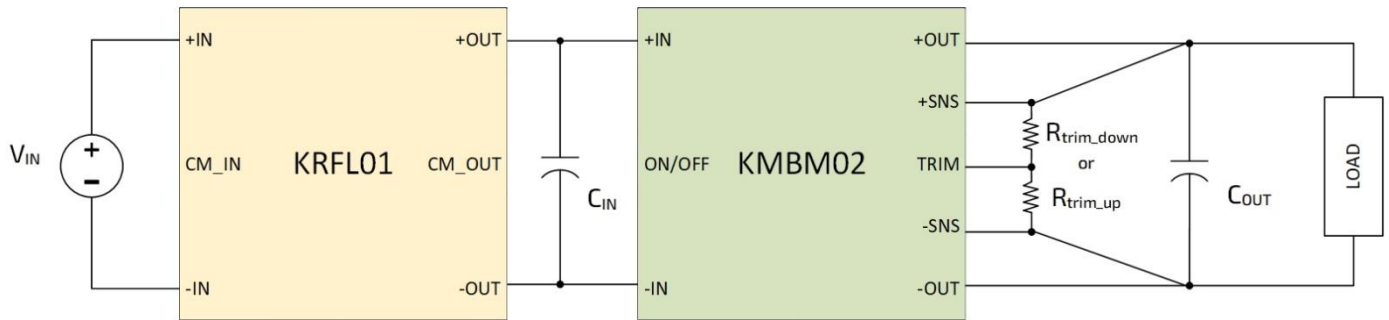

Figure Q. Typical Application

CM_IN and CM_OUT of KRFL01 should be connected to the chassis.

C_{IN}: A759KS476M1KAAE045 (47uF 80V Aluminum-Polymer Capacitor)

C_{OUT}: EEH-ZS1H181UP (180uF 50V Aluminum-Polymer Capacitor)

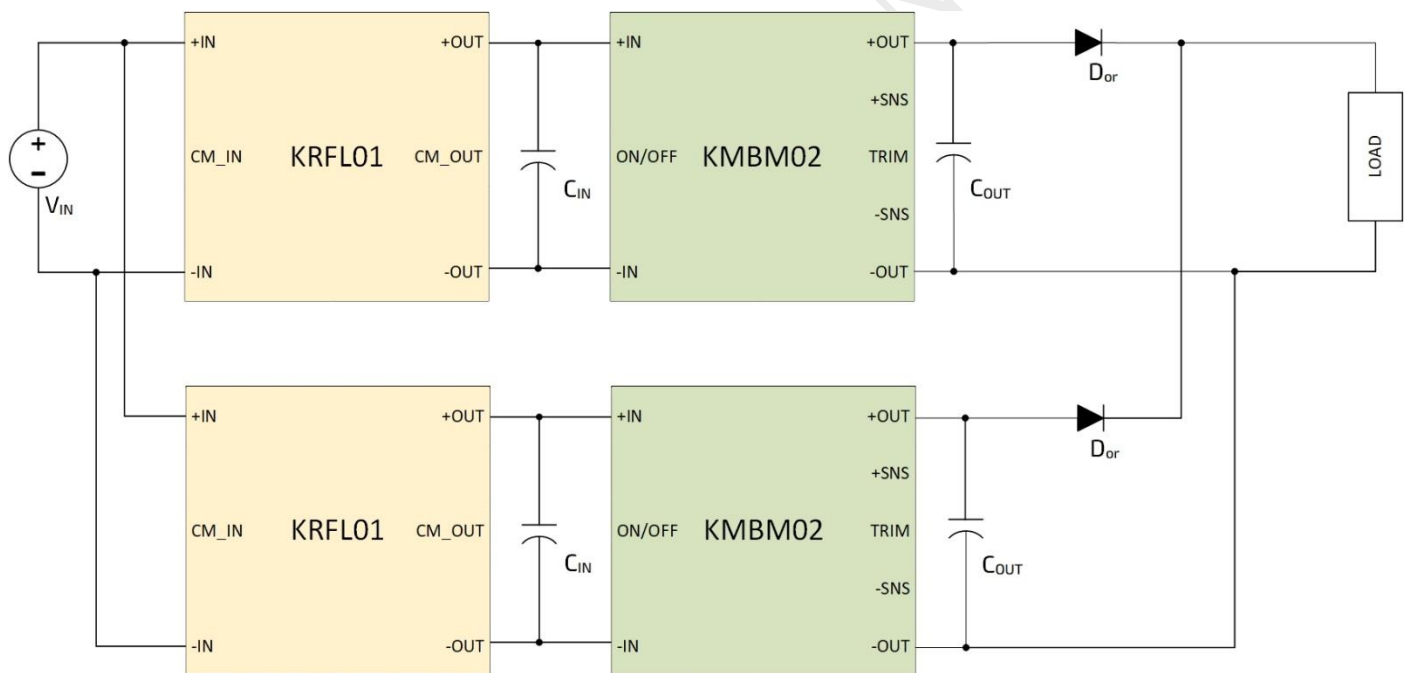

Figure R. Recommended Application N+1 Redundant Parallel Connection

CM_IN and CM_OUT of KRFL01 should be connected to the chassis.

C_V: CHV1206N2K0472KXT (4700 pF 2kV X7R Ceramic Capacitor)

C_{IN}: A759KS476M1KAAE045 (47uF 80V Aluminum-Polymer Capacitor)

C_{OUT}: EEH-ZS1H181UP (180uF 50V Aluminum-Polymer Capacitor)

D_{OR}: Can be either an ORing diode or ideal diode driver circuit

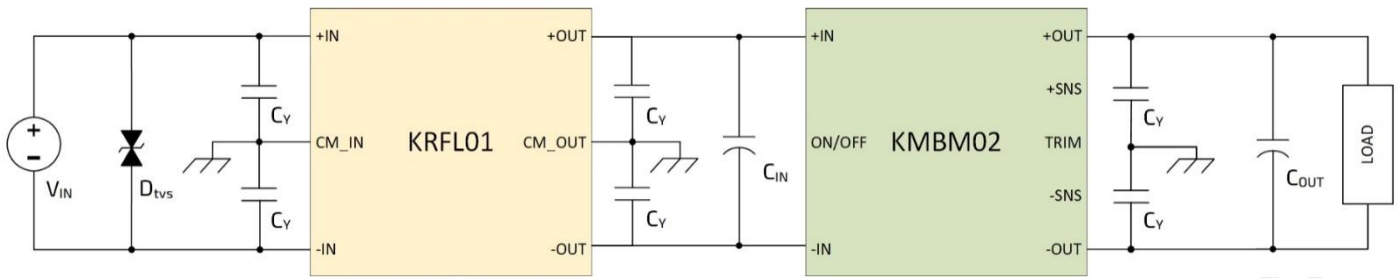

Figure S. Recommended Application for better EMI/EMC compliance

CM_IN and CM_OUT of KRFL01 should be connected to the chassis.

C_Y: CHV1206N2K0472KXT (4700 pF 2kV X7R Ceramic Capacitor)

C_{IN}: A759KS476M1KAAE045 (47uF 80V Aluminum-Polymer Capacitor)

C_{OUT}: EEH-ZS1H181UP (180uF 50V Aluminum-Polymer Capacitor)

D_{TVS}: 5.0SMDJ40CA (Bi-directional 40Vwm TVS Diode)

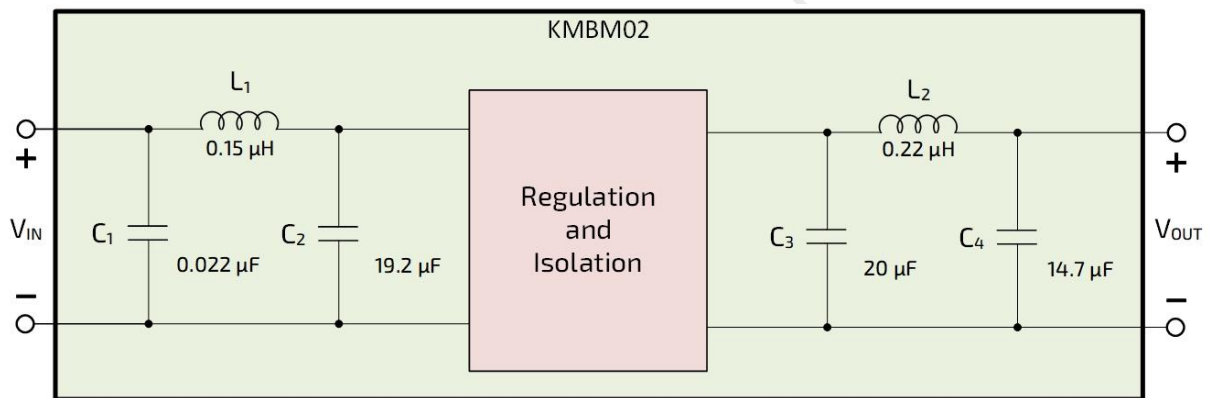
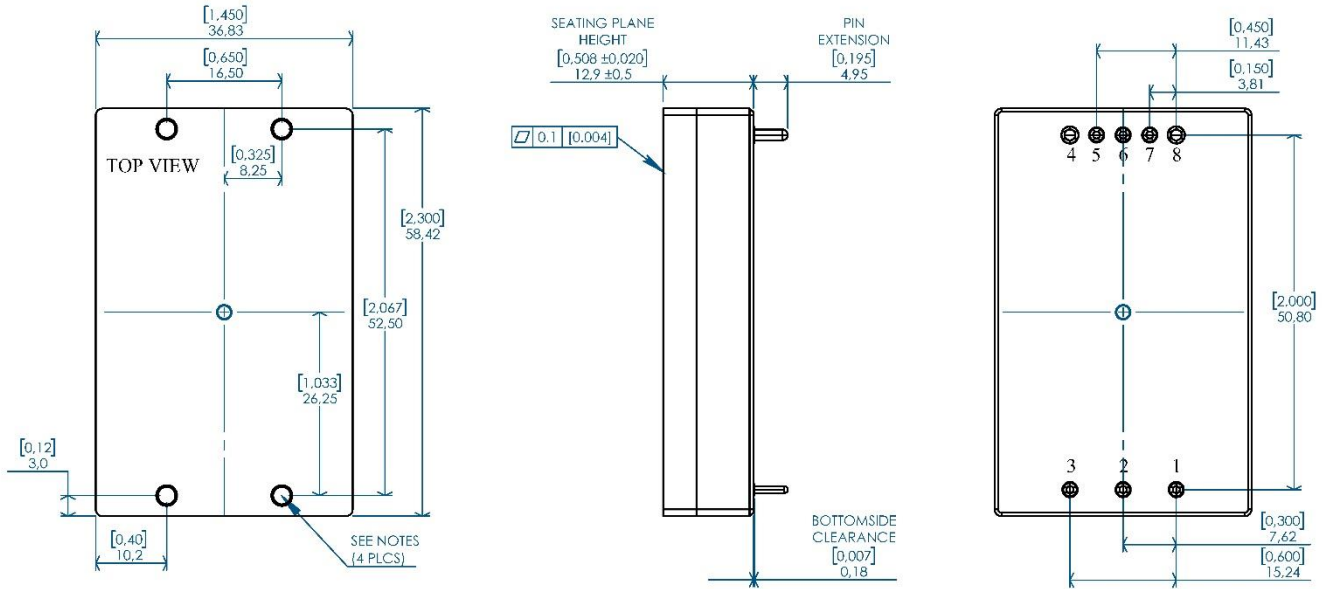

Figure T. Internal input and output filter diagram of KMBM02

Mechanical Drawing – Threaded



NOTES:

- APPLIED TORQUE PER M3 SCREW 0.36Nm (3in-lb) RECOMMENDED [0.4Nm (3.5in-lb) LIMIT]. M3 SCREW SHOULD NOT EXCEED 3mm (0.118") DEPTH BELOW THE SURFACE OF THE BASEPLATE.
- BASEPLATE FLATNESS TOLERANCE IS 0.1mm (0.004") TIR FOR SURFACE.
- PINS 1-3 AND 5-7 ARE 1.02mm DIA. (0.040") WITH 2.03mm DIA. (0.080") STANDOFFS.
- PINS 4 AND 8 ARE 1.57mm DIA. (0.062") WITH 2.54mm DIA. (0.100") STANDOFFS.
- PINS 1-8
MATERIAL: BRASS ALLOY
FINISH: 10 μ m GOLD OVER NICKEL
- WEIGHT: 80.1 g (2.83 oz)
- ALL DIMENSIONS IN MILLIMETERS [inches]
- TOLERANCES: X.Xmm \pm 0.5mm (X.XXIN \pm 0.020)
X.XXmm \pm 0.25mm (X.XXXIN \pm 0.010)

Pin	Name	Function
1	+IN	Positive input voltage
2	ON/OFF	Remote on/off, referenced to -IN
3	-IN	Input return
4	-OUT	Output return
5	-SNS	Negative remote sense
6	TRIM	Output voltage trim
7	+SNS	Positive remote sense
8	+OUT	Positive output voltage

Mechanical Drawing – Flanged

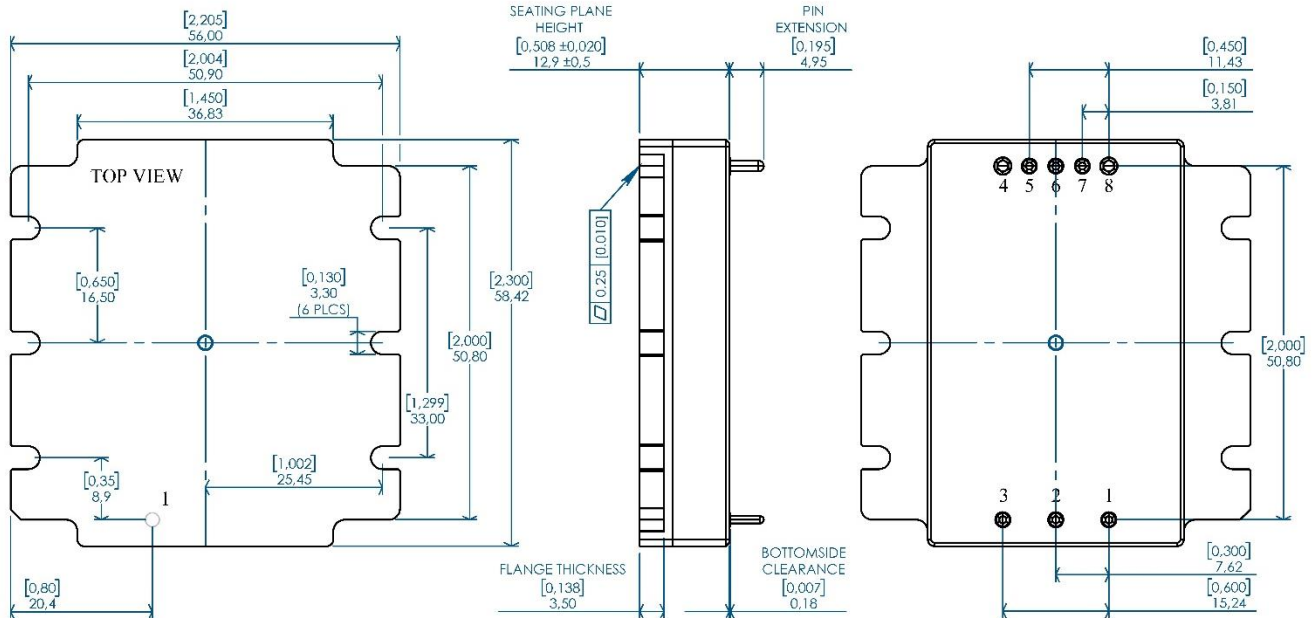

NOTES:

- APPLIED TORQUE NOT TO EXCEED 0.7Nm (6in-lb).
- BASEPLATE FLATNESS TOLERANCE IS 0.25mm (0.010") TIR FOR SURFACE.
- PINS 1-3 AND 5-7 ARE 1.02mm DIA. (0.040") WITH 2.03mm DIA. (0.080") STANDOFFS.
- PINS 4 AND 8 ARE 1.57mm DIA. (0.062") WITH 2.54mm DIA. (0.100") STANDOFFS.
- PINS 1-8
- MATERIAL: BRASS ALLOY
- FINISH: 10µ" GOLD OVER NICKEL
- WEIGHT: 89.0 g (3.14 oz)
- ALL DIMENSIONS IN MILLIMETERS [inches]
- TOLERANCES: X.Xmm ±0.5mm (X.XXIN ±0.020)
X.XXmm =0.25mm (X.XXXIN ±0.010)

Pin	Name	Function
1	+IN	Positive input voltage
2	ON/OFF	Remote on/off, referenced to -IN
3	-IN	Input return
4	-OUT	Output return
5	-SNS	Negative remote sense
6	TRIM	Output voltage trim
7	+SNS	Positive remote sense
8	+OUT	Positive output voltage

Mechanical Drawing – Threaded & PMBUS Capable

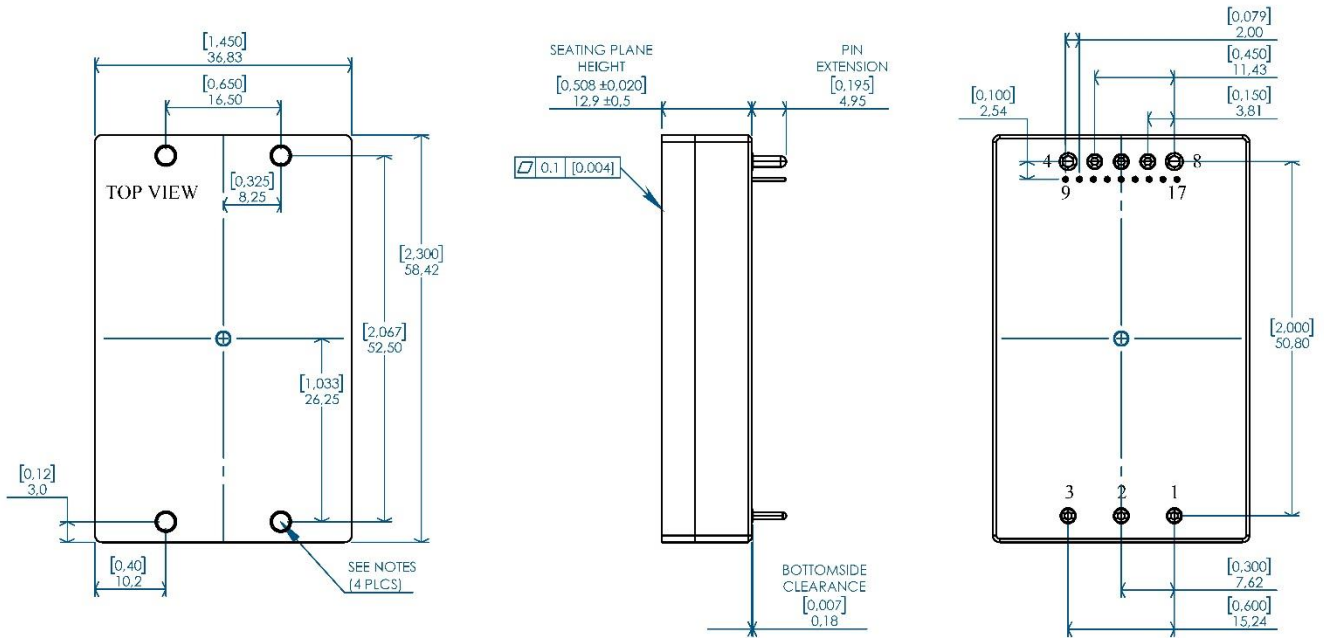

NOTES:

- APPLIED TORQUE PER M3 SCREW 0.36Nm (3in-lb) RECOMMENDED [0.4Nm (3.5in-lb) LIMIT]. M3 SCREW SHOULD NOT EXCEED 3mm (0.118") DEPTH BELOW THE SURFACE OF THE BASEPLATE.
- BASEPLATE FLATNESS TOLERANCE IS 0.1mm (0.004") TIR FOR SURFACE.
- PINS 1-3 AND 5-7 ARE 1.02mm DIA. (0.040") WITH 2.03mm DIA. (0.080") STANDOFFS.
- PINS 4 AND 8 ARE 1.57mm DIA. (0.062") WITH 2.54mm DIA. (0.100") STANDOFFS.
- PM OPTION PINS 9-17 ARE 0.50mm x 0.50mm SQUARE
- PINS 1-8
MATERIAL: BRASS ALLOY
FINISH: 10µ" GOLD OVER NICKEL
- PM OPTION PINS 9-17
MATERIAL: PHOSPHOR BRONZE
FINISH: 10µ" GOLD OVER NICKEL
- WEIGHT: 80.1 g (2.83 oz)
- ALL DIMENSIONS IN MILLIMETERS [inches]
- TOLERANCES: X.Xmm ±0.5mm (X.XXIN ±0.020)
X.XXmm ±0.25mm (X.XXXIN ±0.010)

Pin	Name	Function
1	+IN	Positive input voltage
2	ON/OFF	Remote on/off, referenced to -IN
3	-IN	Input return
4	-OUT	Output return
5	-SNS	Negative remote sense
6	TRIM	Output voltage trim
7	+SNS	Positive remote sense
8	+OUT	Positive output voltage
9*	SYNCH	Active Current Synchronization
10*	DATA-	RS485 Data-
11*	DATA+	RS485 Data+
12*	PMBUS_C2	I2C Control
13*	GND	Digital Ground
14*	PMBUS_SDA	I2C Data
15*	PMBUS_SMBALERT	I2C slave to master alert
16*	PMBUS_SCL	I2C Clock
17*	PMBUS_ADDRESS	I2C address selection

*: AVAILABLE ON PMBUS OPTION

Mechanical Drawing – Flanged & PMBUS Capable

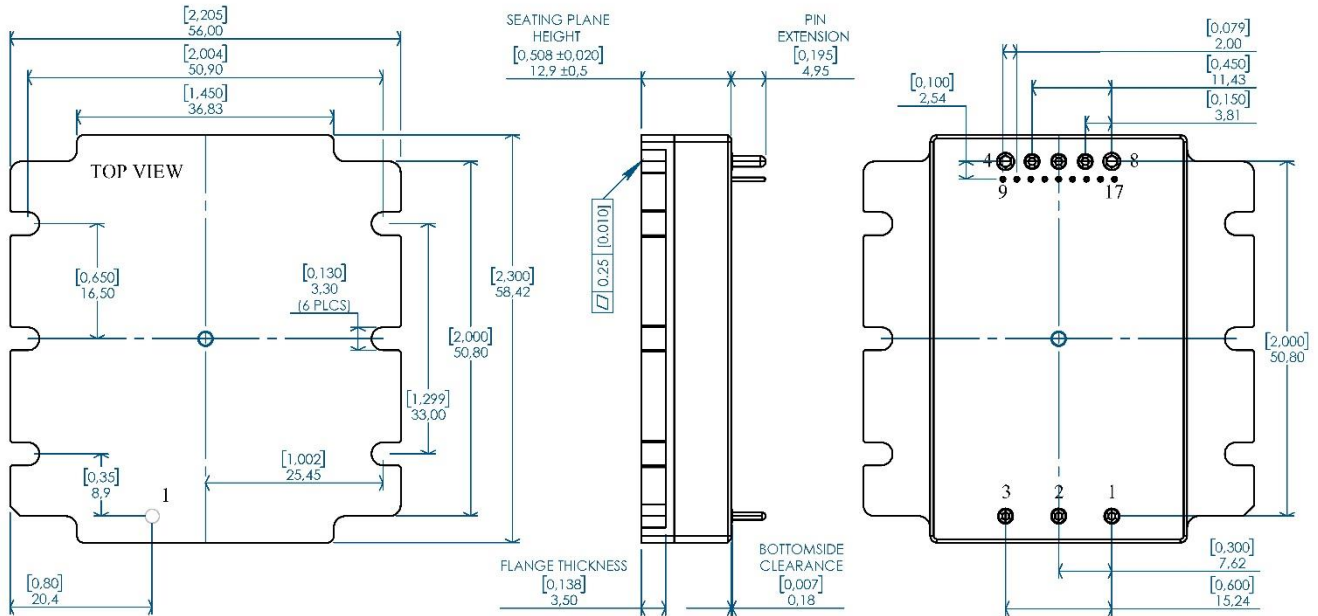

NOTES:

- APPLIED TORQUE NOT TO EXCEED 0.7Nm (6in-lb).
- BASEPLATE FLATNESS TOLERANCE IS 0.25mm (0.010") TIR FOR SURFACE.
- PINS 1-3 AND 5-7 ARE 1.02mm DIA. (0.040") WITH 2.03mm DIA. (0.080") STANDOFFS.
- PINS 4 AND 8 ARE 1.57mm DIA. (0.062") WITH 2.54mm DIA. (0.100") STANDOFFS.
- PM OPTION PINS 9-17 ARE 0.50mm x 0.50mm SQUARE
- PINS 1-8
MATERIAL: BRASS ALLOY
FINISH: 10µ" GOLD OVER NICKEL
- PM OPTION PINS 9-17
MATERIAL: PHOSPHOR BRONZE
FINISH: 10µ" GOLD OVER NICKEL
- WEIGHT: 89,0 g (3.14 oz)
- ALL DIMENSIONS IN MILLIMETERS [inches]
- TOLERANCES: X.Xmm ±0.5mm (X.XXIN ±0.020)
X.XXmm ±0.25mm (X.XXXIN ±0.010)

Pin	Name	Function
1	+IN	Positive input voltage
2	ON/OFF	Remote on/off, referenced to -IN
3	-IN	Input return
4	-OUT	Output return
5	-SNS	Negative remote sense
6	TRIM	Output voltage trim
7	+SNS	Positive remote sense
8	+OUT	Positive output voltage
9*	SYNCH	Active Current Synchronization
10*	DATA-	RS485 Data-
11*	DATA+	RS485 Data+
12*	PMBUS_C2	I2C Control
13*	GND	Digital Ground
14*	PMBUS_SDA	I2C Data
15*	PMBUS_SMBALERT	I2C slave to master alert
16*	PMBUS_SCL	I2C Clock
17*	PMBUS_ADDRESS	I2C address selection

*: AVAILABLE ON PMBUS OPTION

Part Ordering Information

Family	Input Voltage	Power	Output Voltage	Package	Option Field
KMBM02	DC28 28 VDC	P300 300 W	DC28 28 VDC	QB Quarter Brick	F: Flanged PM: PMBUS PR: Droop Active

Ordering Number	Baseplate	Communication	Droop
KMBM02-DC28-P300-DC28-QB	Threaded	No communication capability, PMBUS pins are absent.	Passive
KMBM02-DC28-P300-DC28-QB-F	Flanged	No communication capability, PMBUS pins are absent.	Passive
KMBM02-DC28-P300-DC28-QB-PR	Threaded	No communication capability, PMBUS pins are absent.	Active
KMBM02-DC28-P300-DC28-QB-F-PR	Flanged	No communication capability, PMBUS pins are absent.	Active
KMBM02-DC28-P300-DC28-QB-PM	Threaded	With PMBUS communication capability	Passive
KMBM02-DC28-P300-DC28-QB-F-PM	Flanged	With PMBUS communication capability	Passive
KMBM02-DC28-P300-DC28-QB-PM-PR	Threaded	With PMBUS communication capability	Active
KMBM02-DC28-P300-DC28-QB-F-PM -PR	Flanged	With PMBUS communication capability	Active

Not Recommended for New Designs

Revision History

Revision	Date	Description	Page Number(s)
A-PC1	10.07.2022	Initial Release	-
A-PC2	11.10.2022	- Output ripple value is corrected.	2
A-PC3	29.11.2022	- Input Voltage Range updated. - ON/OFF circuit updated. - Efficiency updated.	2, 10
A-PC4	09.12.2022	- General organizing.	1, 2, 10, 11
A-PC5	10.12.2022	- Output Voltage updated.	2
A-PC6	15.08.2023	- General organizing.	All
A-PC7	19.08.2023	- ON/OFF pin voltage ranges updated	3
A-PC8	25.10.2024	- Status updated to "Not Recommended for New Designs"	-

Contact

KOLT Mühendislik A.Ş.

Phone: +90 312 354 47 06

E-Mail: KSG@kolt.com.trWeb: www.kolt.com.tr

Address: Ostim OSB Mah. 1148. Sok. No:32/B1 – 06374

Yenimahalle / Ankara / TÜRKİYE

Not Recommended for New Designs